



BEVERAGE-AIR

Project: _____	AIA#
Item: _____	SIS#
Location: _____	
Approved: _____	

WTRCS COOKSTAND REFRIGERATOR

WTRCS72D-1 76" Worktop Refrigerator with Four Drawers

MODEL:
WTRCS72D-1-76

WTRCS72D-1 Refrigerator with 4 Drawers: Worktop Series

3 Year Parts/Labor Warranty
Additional 2 Year Compressor Warranty

CABINET CONSTRUCTION

- Stainless steel front, sides, drawers and grille (galvanized back & bottom)
- Interior liner is made of corrosion resistant aluminum
- Full electronic control
- 76" Worktop
- Drawers provide ample food product storage
- Full marine drip-guard to prevent spills from dripping over the edge
- Dynamic load rating of 275 lbs per drawer
- 12 gauge drawer slides with 3 Delrin encased stainless steel roller bearings per each drawer slides - *LIFETIME WARRANTY ON ALL DRAWERS AND SLIDES*
- Heavy duty, fire-proof, reinforced insulated 16 gauge top
- Accommodates 6" deep pans in top & bottom drawers
- Self-closing feature engages in the last 1-2" of travel
- 6" Casters, 3 with brakes standard
- Operates at 36°-38°F for optimum food preservation

REFRIGERATION SYSTEM

- Refrigeration system uses R134a refrigerant to comply with all environmental concerns
- Automatic, non-electric defrost
- Epoxy coated evaporator coil



WTRCS72D-1-76

OPTIONS & ACCESSORIES

- 6" Legs
- 3" Casters
- Gasket guards
- Worktop size options
- Flat top option
- Remote option



3779 Champion Blvd., Winston-Salem, NC 27105
1-888-845-9800 Fax: 1-336-245-6453
Beverage-Air.com sales@bevair.com



BEVERAGE-AIR

Worktop Refrigerator– With 4 Drawers

Models: WTRCS72D-1-76

MODEL	WTRCS72D-1-76
EXTERNAL DIMENSIONAL DATA	
Width Overall (Cabinet)	72"
Width Overall (Worktop)	76"
Depth Overall with Handle & Bumper	34 3/4"
Height Overall with 6" Casters	26 5/8"
Number of Drawers	4
Depth with Drawer Extended	57 3/4"
Drawer Opening (in)	Upper 27 3/8" x 6 1/2" (R) Lower 27 3/8" x 6 1/2" (L)
INTERNAL DIMENSIONAL DATA	
NET Capacity (cubic ft.)	14.29
Internal Width Overall (in)	58"
Internal Depth Overall (in)	26"
Internal Height Overall (in)	16"
ELECTRICAL DATA	
Full Load Amperes 115/60/1	4.5
REFRIGERATION DATA	
Horsepower	1/3
Capacity (BTU/Hr)*	1690
WEIGHT DATA	
Gross Weight (Crated lbs)	600 lbs
Height - Crated	26"
Width - Crated	89"
Depth - Crated	38"

Drawers

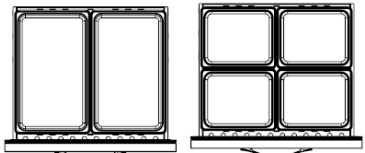

FULL PANS

HALF PANS

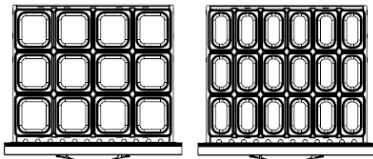

SIXTH PANS

NINTH PANS

Model Views

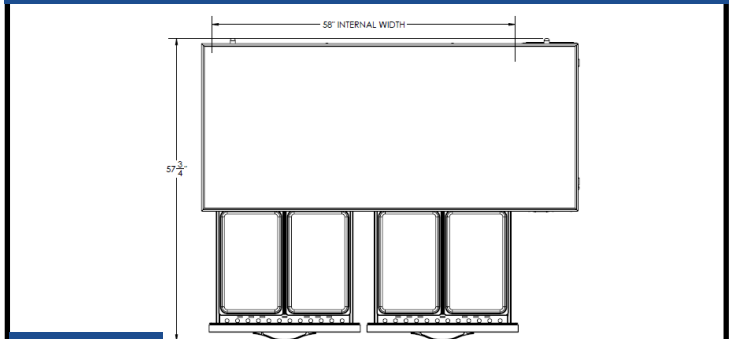

Plan View

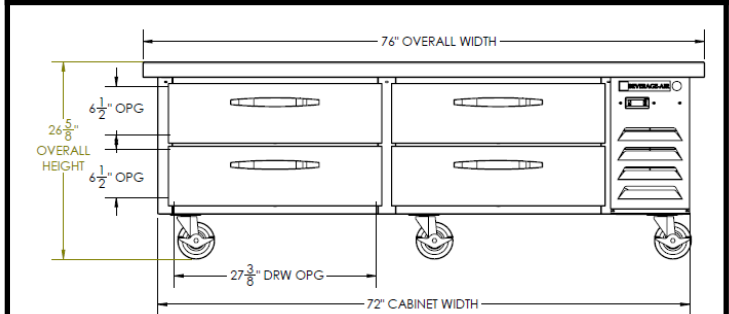

Elevation View

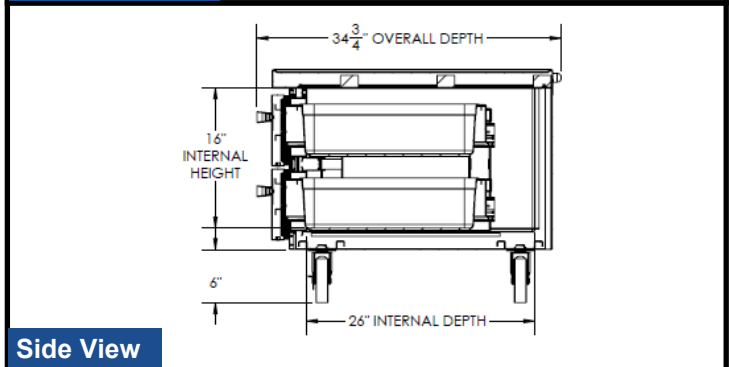

Side View

ELECTRICAL CONNECTION



115/60/1
NEMA-5-15P

Units pre-wired at factory and include 8' long cord and plug set.



an Ali Group Company



The Spirit of Excellence

3779 Champion Blvd., Winston-Salem, NC 27105
1-888-845-9800 Fax: 1-336-245-6453
Beverage-Air.com sales@bevair.com