

Automatic slicer w/LED safety

BIZERBA■ **Food Service**

Bizerba GSP series slicers are certified to the new NSF/ANSI 8-2012 standard.

Safety is our top-priority ...

... GSP HD i 90 series – automatic safety slicer ...

New safety illuminated dial!

Green means motor off
gauge plate closed.



Red means gauge plate
open or motor running.



Emotion
Efficient in energy ...



- **Energy Savings – average of 50% savings over competitors' models**
- Widest product carriage for increased capacity
- One piece anodized aluminum construction
- Fast and easy to clean, fewer seams, large radii
- Improved sealing against water and debris
- Largest and easiest to use remnant holder with 306 holding points
- Unique design allows for the smallest end pieces, increased product yield
- The ability to adjust both the speed and the stroke of the carriage "on-the-fly" will speed up your operation
- The ergonomic design of the Bizerba GSP HD series sets the standard for safety, yield, hygiene, durability, and lowest overall cost of ownership
- Safety features: Shut off in slice thickness knob, adjustable blade shut off and start at zero (safe-only)
- Improved liquid and debris diversion from all control surfaces
- 3.5"W x 11.13"H x 2.6" D thumb guard wall for maximum protection
- Zero blade exposure during the cleaning process
- Remote sharpener is dishwasher safe for improved safety and hygiene
- One piece carriage with seamless thumb guard for highest hygiene standards
- Servo assist function reduces operator fatigue during manual mode
- Top quality gravity feed slicer with low-profile carriage for heavy product

Best blade in the industry

The unique design of our blade produces clean and consistent slices. The hardness results in a long lasting sharp edge. The life of the blade is dramatically longer than the competition. Our standard blade is the hardest, thinnest, largest, straightest blade in the industry.

- 13" diameter, chromium coated hard alloy
- 60-62 Rockwell hardness at the edge
- Accurate slicing on meats and even the most demanding cheese products over a wide temperature range



Model #: GSP HD i 90 | Stock #: 913004015

C.S.I. Division 11 | Section 400

Project Name: _____ AIA # _____

Location: _____ SIS # _____

Item Number: _____

Quantity: _____

BIZERBA

Food Service

Emotion^(R) Technology - Variable Frequency Drive Motor

- 120 V, specialized data available on request
- 60 Hz | 1-phase AC current
- Frequency of nominal current 2.6 A
- Power consumption 0.240 kW
- Energy savings up to 60%
- Idle-running requires 45% less energy
- Stand-by mode 0.0 kW energy usage
- Cutting performance adapts to cutting resistance of the product
- Less heating of machine, cooler food-zone surface

Blade diameter

- 13" (330 mm)

Blade speed

- 255 r.p.m.

Max. produce size

- Round: 7.95" (202 mm)
- Height: 4.96" (126 mm)
- Width: 11.42" (290 mm)

Strokes per minute

- Full: 30-40-50
- Mid: 35-48-58
- Short: 60-68-75

Slice thickness

- 0-0.94" (0-24 mm), infinitely variable

Thumb-guard rear wall

- 3.5"W x 11.13"H x 2.6"D (90 x 235 x 67 mm)

Gravity-feed slicing carriage

- 40° inclined gravity feed

H - Carriage inclination

- Carriage inclined 25° towards operator
- Carriage height positioned towards center of blade

Noise control drive system

- ~68.5 dB level - a 20% reduction in decibel pollution

Installation area

- (L x W) 20.94" x 17.48" (532 x 444 mm)

External dimensions

- (L x W x H) 28.5" x 22.48" x 24.67" (724 x 571 x 627 mm)

Operating area

- (L x W) 31.73" x 35.39" (806 x 899 mm)

Food Safety - Ingress Protection type

- IP Solids level 3 | Liquids level 3

Weight of machine

- 122 lbs, 55 kg

Shipping Details & Dimensions

- Total Shipping Dimensions (L x W x H): 32.5" x 27.8" x 32" (826 x 706 x 813 mm)
- Total Shipping Weight: 150 lbs, 68 kg
- Cubic: Ft. 16.89, 0.48 m
- Density: 8.88 lb/cubic ft, 142.6 kg/cubic m

Additional equipment

- Vegetable chute 7" dia x 12"L (178 x 350 mm), 3 lb (1.36 kg) easy-gliding stomper
- 2" H (51 mm) Product fence
- Equipment Stand
- Extended Warranty
- 13" (330 mm) Grooved Cheese Blade

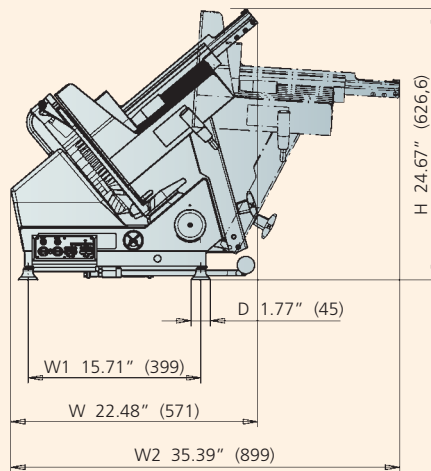
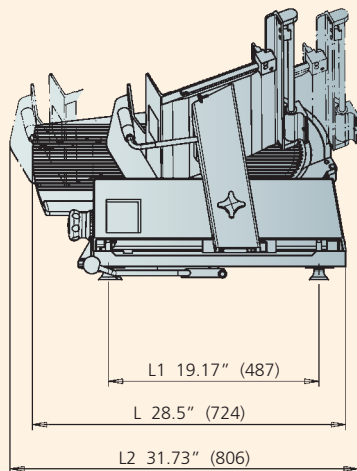

Warranty

The GSP HD Safety Slicer carries a one-year, on-site parts and labor warranty against any flaws in materials and workmanship. This period begins with the date of purchase and, provided the unit is used properly in accordance with our instructions, is in full effect for one year from that date. Any work to be performed under this warranty must be performed between the hours of 8:00 a.m. and 4:30 p.m. local time, Monday to Friday. Bizerba will not pay overtime charges for work performed other than during normal business hours. Accessories have a 30-day replacement or repair warranty for the period beginning on the date of purchase. Damages incurred in transit or from installation error, accident, alteration or misuse are not covered. Transit damages should be reported to the carrier immediately. Bizerba shall not be liable for any consequential, compensatory, incidental, or special damages. All warranty work must be performed by a factory authorized Bizerba Representative.

Members of the Bizerba Group

Bizerba GmbH & Co. KG
Wilhelm-Kraut-Straße 65
72336 Balingen
Germany
Tel. +49 7433 12-0
Fax +49 7433 12-2696
marketing@bizerba.de
www.bizerba.com

Bizerba USA Inc.
1804 Fashion Court
Joppa, MD 21085
USA
Tel. Office +1 732 565-6000
Tel. Service +1 732 565-6001
Fax +1 732 819-0429
us.info@bizerba.com
www.bizerba.com

Bizerba Canada Inc.
2810 Argentinia Road #9
Mississauga,
Ontario L5N 8L2
Canada
Tel. +1 905 816-0498
Fax +1 905 816-0497
ca.info@bizerba.com
www.bizerba.ca

Bizerba de México, S.A. de
C.V. Av. Rio Mixcoac No. 157
Colonia Florida
01030 México, D.F.
México
Tel. +52 55 5663-1397
Fax +52 55 5663-1296
contacto@bizerba.com.mx
www.bizerba.com.mx