

BIZERBA■ **Food Service**

Bizerba VS 12 D-V series slicer certified to the stringent NSF/ANSI 8-2012 standard.

The VS 12 D-V series features a vertical carriage with a positive product feed. This allows for consistent, thin slices. The automatic version has a built-in

diagnostic program for easy troubleshooting. The VS 12 D-V series incorporates all the safety features one expects with Bizerba products.

... VS 12 D-V-SYS – automatic slicer system...

Horizontal carriage with positive product feed insures consistent slices. Features Emotion technology – uses 50% less energy

Emotion
Efficient in energy...



VS 12 D-V-1

VS 12 D-V-SYS automatic slicer & stand

- Shingle, stack, circular patterns
- Shingling in 3 rows, traditional or transverse, multi-layer
- Stacking up to 4 stacks with one product, 2.5" max. height
- Circular presentations in 3 diameters
- Adjustable 3 speeds and 3 strokes
- Built in diagnostic program
- All the features of VS 12 D
- Large carriage for full production: 20" x 10.5"
- Will fit 15" long product without re-clamping
- Top quality horizontal carriage with positive feed

Installation, Start-up and Demo (ISD)

Included with purchase, count on us for a proper ISD!

- Bizerba ISD includes labor and travel time during normal and local Bizerba working hours within the (50) U.S., please contact Bizerba for scheduling your ISD, toll-free 1-800-229-3115 or email: us.service@bizerba.com.

Best blade in the industry

The unique design of our blade produces clean and consistent slices. The hardness results in a long last-ing sharp edge. The life of the blade is dramatically longer than the competition. Our standard blade is the hardest, thinnest, largest, straightest blade in the industry.

- 13" diameter, chromium coated hard alloy
- 60-62 Rockwell hardness at the edge

Optional accessories:

- Round platter for star shaped presentations
- Mobile Stand for the correct working height

B56-BZ-1 Stand

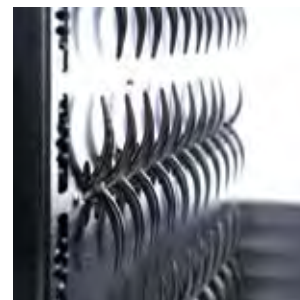

Model #: VS 12 D-V-SYS | Stock #: 193701-SYS

C.S.I. Division 11 | Section 400

Project Name: _____ AIA # _____

Location: _____ SIS # _____

Item Number: _____

Quantity: _____

BIZERBA

Food Service

Emotion Variable Frequency Drive Motor

1-phase AC current

- 230/120 V, specialized data available on request
- 50/60 Hz
- Frequency of nominal current 2.5/4.2 A
- Power consumption 0.575/0.504 kW

3-phase AC current

- 230/400 V, specialized data available on request
- 50 Hz
- Frequency of nominal current 1.9/1.38 A
- Power consumption 0.552 kW

Protection type

- IP 33

Blade diameter

- 13" (330 mm)

Blade

- 266 r.p.m.

Strokes/min

- full: 30/40/50 mid: 35/48/58 short: 60/68/75

Slice thickness

- 0.02" to 0.94" (0.5 to 24 mm), infinitely variable

Installation area

- VS 12 D-V: (L x W) 20.3 x 16.9" (515 x 430 mm)

Space required

- VS 12 D-V: (L x W) 32.5 x 40.9 (825 x 1040 mm)

Weight of machine

- VS 12 D-V: approx. 165 lbs /75 kg (net)
approx. 191.4 lbs/84 kg (gross)

Receiving tray

- 10" x 13.6" (254 x 346 mm)

Packing case

- (L x W x H) 33.5" x 32.3" x 27.6"
(850 x 820 x 700 mm)

Paper size

- 1/8 sheet – 9.8" x 14.8" (250 x 375 mm)

Table displacement

- 6.3" (160 mm)

Additional equipment

- Round platter for star-shaped product layout,
Teflon blade, product clamping device

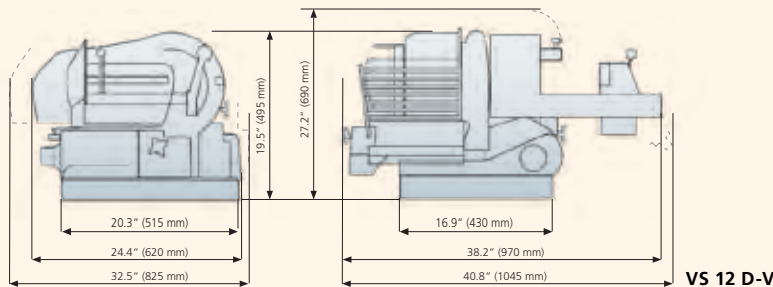
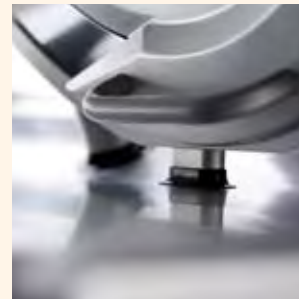
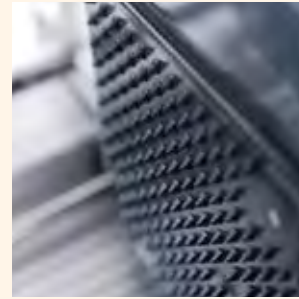

Warranty

The VS 12 D-V carries a one-year, on-site parts and labor warranty against any flaws in materials and workmanship. This period begins with the date of purchase and, provided the unit is used properly in accordance with our instructions, is in full effect for one year from that date. Any work to be performed under this warranty must be performed between the hours of 8:00 a.m. and 4:30 p.m. local time, Monday to Friday. Bizerba will not pay overtime charges for work performed other than during normal business hours. Accessories have a 30-day replacement or repair warranty for the period beginning on the date of purchase. Damages incurred in transit or from installation error, accident, alteration or misuse are not covered. Transit damages should be reported to the carrier immediately. Bizerba shall not be liable for any consequential, compensatory, incidental, or special damages. All warranty work must be performed by a factory authorized Bizerba Representative.

Members of the Bizerba Group

Bizerba GmbH & Co. KG
Wilhelm-Kraut-Straße 65
72336 Balingen
Germany
Tel. +49 7433 12-0
Fax +49 7433 12-2696
marketing@bizerba.de
www.bizerba.com

Bizerba USA Inc.
1804 Fashion Court
Joppa, MD 21085
USA
Tel. Office +1 732 565-6000
Tel. Service +1 732 565-6001
Fax +1 732 819-0429
us.info@bizerba.com
www.bizerba.com

Bizerba Canada Inc.
2810 Argentinia Road #9
Mississauga,
Ontario L5N 8L2
Canada
Tel. +1 905 816-0498
Fax +1 905 816-0497
sales@bizerba.ca
www.bizerba.ca

Bizerba de México, S.A. de C.V.
Av. Rio Mixcoac No. 157
Colonia Florida
01030 México, D.F.
México
Tel. +52 55 5663-1397
Fax +52 55 5663-1296
eduardo.aburto@bizerba.com.mx
www.bizerba.com.mx

B56-BZ-1 Work Table Equipment Stand

Rolling working table with retractable wheels for optimum versatility. Provides excellent stability and correct working height for the full range of Bizerba products. Including the GSP manual & automatic safety slicers, 350M-VS12F-Prosciutto slicer, VS 12 D-V fully automatic slicer, VS 12 F & F-P manual slicer, and B 100 bread slicer.

SPECIFICATIONS

1. Stainless Type 304 steel top with rolled edge and open rounded front corners.
2. Stainless Type 304 stainless steel tubular frame construction.
3. Stainless Type 304 stainless steel height adjustable feet with 7.5 degree angular misalignment and high coefficient friction 3.5" diameter padded shoes.
4. Heavy Duty Type 304 stainless steel lower shelf.
5. Slide out removable Polsan mid-shelf.
6. Left handle grip.
7. Tall ergo-style right handle.
8. Heavy duty work station with four (4) retractable ball bearing wheels, "Center Pivot Design". Standard galvanized undercarriage caster channel mounting brackets and linkage. Optional - 304 stainless steel undercarriage available.
9. Low center of gravity counter-weighted frame.

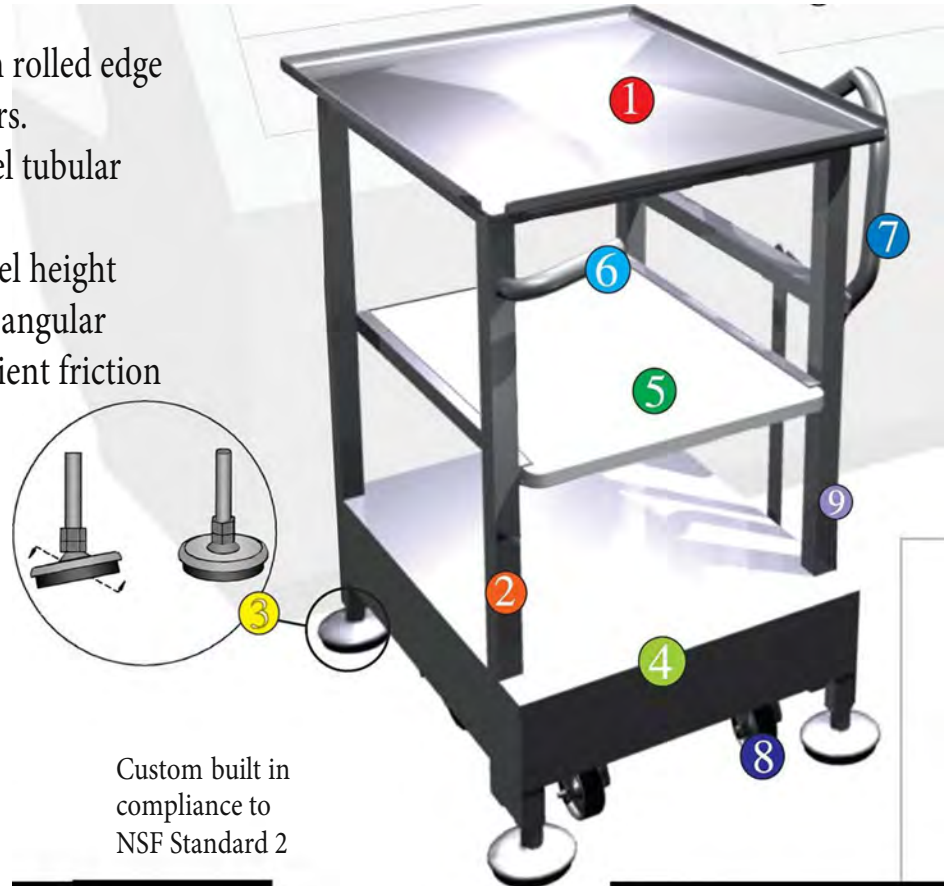

Custom built in compliance to NSF Standard 2



Warranty

The Bizerba B56-BZ-1 work table equipment stand carries a one-year, on-site parts and labor warranty against any flaws in materials and workmanship. This period begins with the date of purchase and, provided the unit is used properly in accordance with our instructions, is in full effect for one year from that date. Any work to be performed under this warranty must be performed between the hours of 8:00 a.m. and 4:30 p.m. local time, Monday to Friday. Bizerba will not pay over-time charges for work performed other than during normal business hours. Accessories have a 30-day replacement or repair warranty for the period beginning on the date of purchase. Damages incurred in transit or from installation error, accident, alteration or misuse are not covered. Transit damages should be reported to the carrier immediately. Bizerba shall not be liable for any consequential, compensatory, incidental, or special damages. All warranty work must be performed by a factory authorized Bizerba Representative.

Bizerba USA Inc.
Bizerba North America
1804 Fashion Court
Joppa, MD 21085
USA
Tel. Office +1 732 565-6000
Tel. Service +1 732 565-6001
Fax +1 732 819-0429
us.info@bizerba.com
www.bizerba.com

B56-BZ-1

Project Name _____
 Model/s _____
 Number _____
 Quantity _____

C.S.I. Division 11 | Section 400

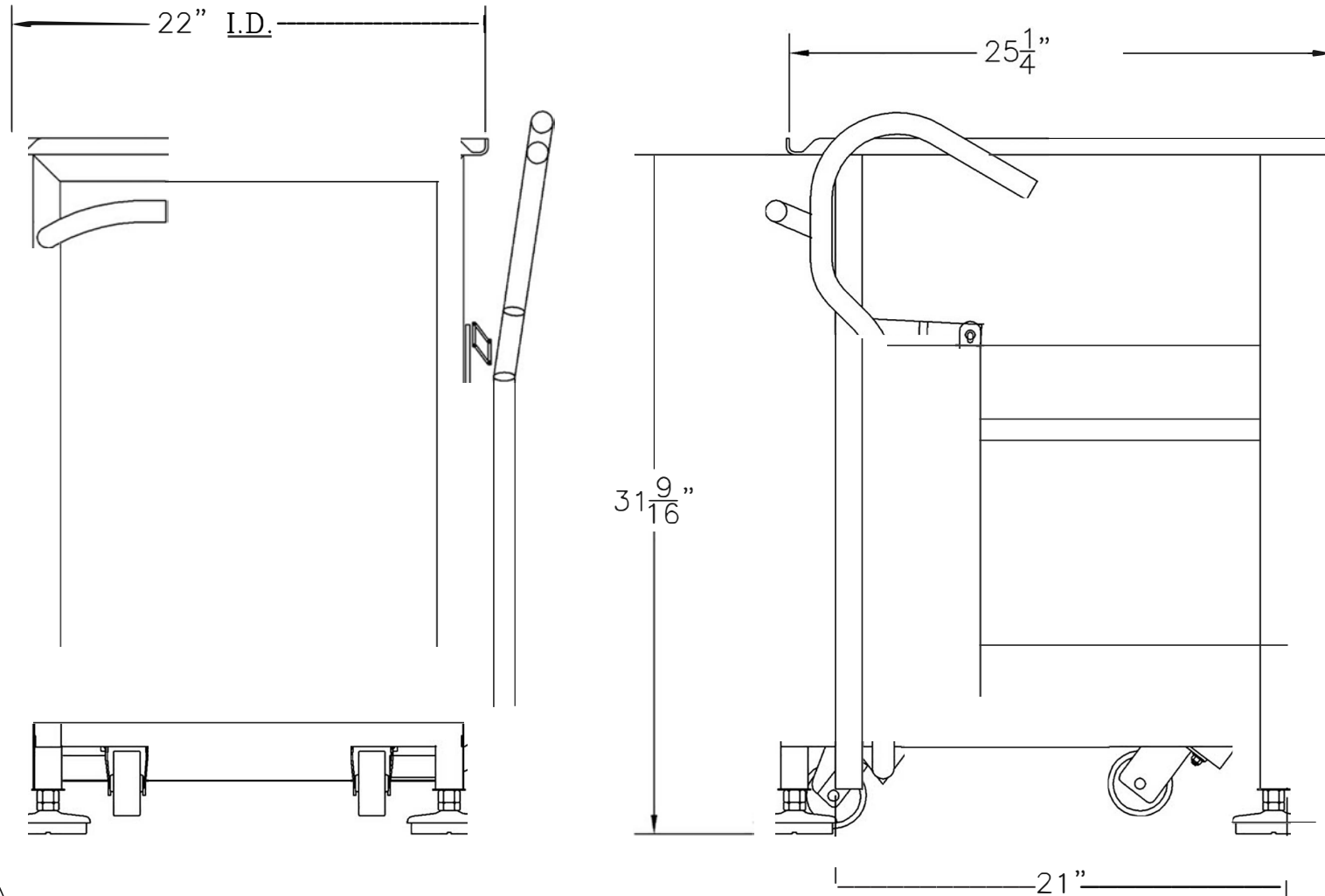

Custom built in compliance with NSF Standard 2 Bizerba Revised 12/01/2016

Bizerba Equipment Stand by M&E Mfg. Co., Inc. covered by one or more of the following U.S. Patents: 5,330,064; 5,386,787; 5,471,922; 5,503,087; 5,628,522; 5,957,309; 6,062,401, 6,149,120; 6,322, 180; 6,366,313; 6,474,757; 6,974,042; 7,419,063; D480,528; D481,513 & Canadian patent 2,169,336. Other U.S. & foreign patents pending.

