



Item No. _____

7qt PLANETARY MIXER BMPM007

Features:

- Gear driven.
- Professional countertop style.
- 650 Watt motor offers enough power to mix stiffer doughs and larger batches.
- All metal and die-cast aluminum body.
- Transmission is made of hardened alloy steel gears.
- All shafts are mounted in ball bearings.
- Automatic electronic 5 speed control.
- Planetary mixing action ensures perfect results.
- Simple hand lift for tool change and bowl removal.

Other specifications:

- 7 qt stainless steel bowl.
- Digital timer.
- Includes dough hook, flat beater and wire whip.
- Safety guard is standard for model BMPM007 and provides with automatic shut-off when guard is opened at any speed.
- Plug N' Go electrical for easy installation.



The BakeMax[®] Planetary Mixers provide durability, long life and excellent mixing performance. Gear driven, direct drive with 30 minute digital timer and 5 speed digital control. 100 to 500 RPM.

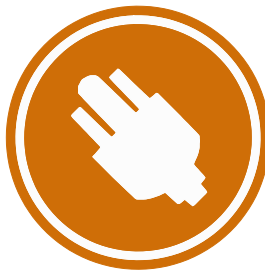

Think Quality, Value, Service.....Think

BakeMax[®]

7qt PLANETARY MIXER BMPM007

Volume

External and Internal Dimensions (D x W x H)

| Model | External |
|---------|-----------------|
| BMPM007 | 19" x 12" x 21" |

Capacity Chart (approx.)

| Product | Tool | Amount |
|-------------------------|--------|--------|
| Egg White | Whip | 0.4L |
| Whipping Cream | Whip | 1.8L |
| Mayonnaise (oil) | Whip | 1.8L |
| Sponge cake (egg/sugar) | Beater | 2 kg |
| Mashed Potatoes | Beater | 1.8 kg |
| Biscuits/Cookies | Beater | 1.5 kg |
| Bread Dough | Hook* | 2 kg |

* 1st speed

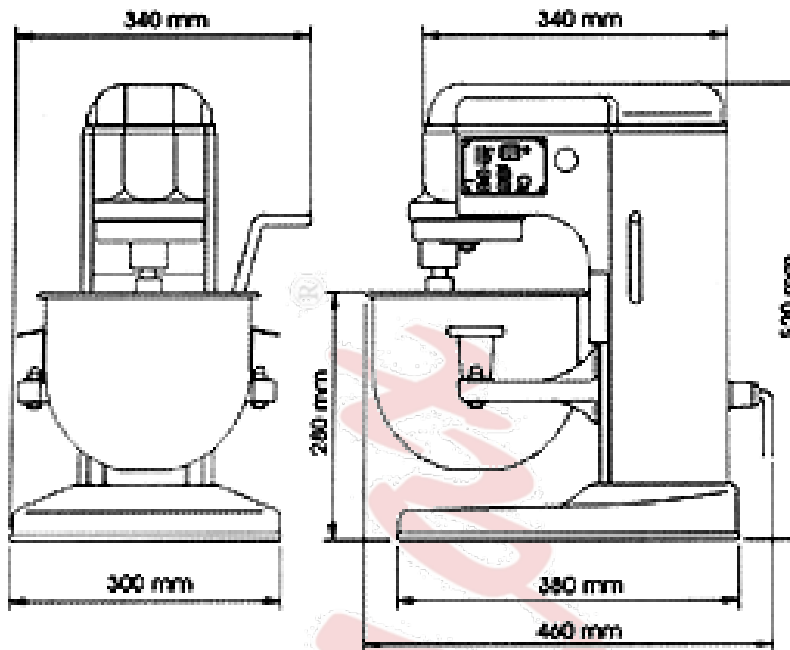

Electrical Information

| Model | Voltage | Phase | Amps | Watts | HP | Hertz | NEMA |
|---------|---------|-------|------|-------|-----|-------|-------|
| BMPM007 | 110 | 1 | 6 | 650 | 3/4 | 50/60 | 5-15P |

Shipping Information

| Model | Net Weight | Crated Weight | Crate Dimensions (D x W x H) |
|---------|-----------------|---------------|------------------------------|
| BMPM007 | 50lbs / 22.5 kg | 45lbs / 20 kg | 19.5" x 15" x 24" |



Authorized Dealer:



BakeMax Manufacturing, Inc.
170 Millennium Blvd, Moncton, NB, E1C 1M8
Toll Free: 1-800-565-BAKE
Telephone: 1-506-858-8990
Fax: 1-506-859-6929

Think Quality, Value, Service.....Think

BakeMax[®]

Toll Free: 1-800-565-BAKE

Web Site: www.bakemax.com

E-mail: sales@bakemax.com

Printed in Canada