

This Space for Architect/Engineer Approval

Job Name _____ Date _____

Model Specified _____ Quantity _____

Customer/Wholesaler _____

Contractor _____

Architect/Engineer _____

EPAct 2005 Compliant

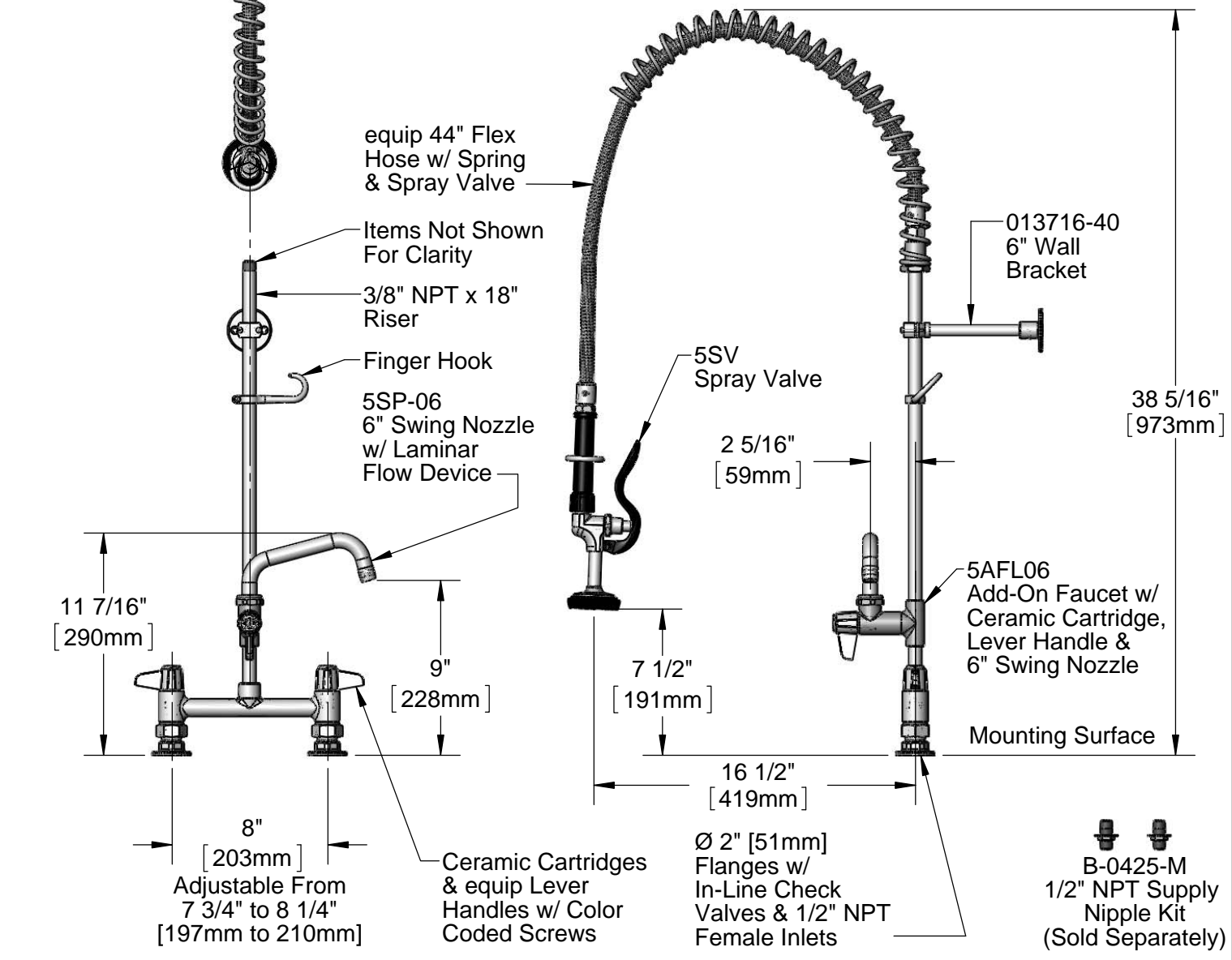

Model Number 5PR-8D06	Date 08/08/12	Scale 1:8	Drawn DHL	Checked DMH	Approved JHB
---------------------------------	-------------------------	---------------------	---------------------	-----------------------	------------------------



Product Specifications:

Pre-Rinse Unit: 8" Deck Mount Mixing Faucet w/ Ceramic Cartridges, Add-On Faucet w/ 6" Swing Nozzle, 5SV Spray Valve, 6" Wall Bracket, In-Line Check Valves & 1/2" NPT Female Inlets

equip Foodservice Accessories
 2 Saddleback Cove, P.O. Box 1088
 Travelers Rest, South Carolina 29690
 Phone: 800.891.4808 Fax: 800.868.0084

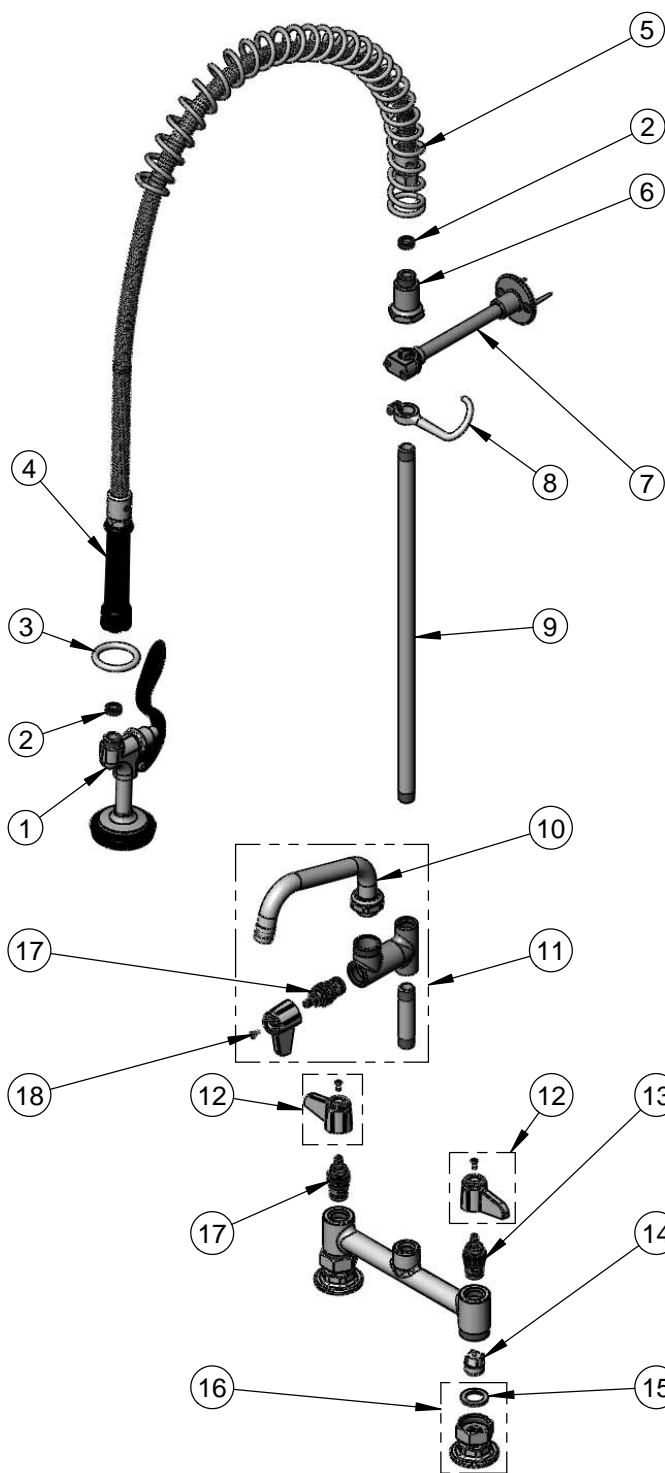

ITEM NO.	SALES NO.	DESCRIPTION
1	5SV	equip Spray Valve
2	010476-45	#27 Washer
3	000907-45	Spray Valve Hold Down Ring
4	5HSE44	44" Flex Hose Assembly (Includes Washer)
5	014068-45	Overhead Spring
6	000821-40	Spring Body
7	013716-40	6" Wall Bracket
8	004R	Finger Hook
9	000369-40	3/8" NPT x 18" Long Riser
10	5SP-06	equip 6" Swing Nozzle
11	5AFL06	Add-On Faucet w/ 6" Swing Nozzle
12	5-HDL-L	equip Lever Handle w/ Color Coded Screws
13	013788-45	equip Ceramic Cartridge, LTC
14	013840-45	20mm Check Valve (2)
15	001019-45	Coupling Nut Washer
16	00AA	1/2" NPT Female Inlet Flange
17	013787-45	equip Ceramic Cartridge, RTC
18	013849-45	Screw, 4mm Metric (10)

Model Number 5PR-8D06	Date 08/08/12	Scale NTS	Drawn DHL	Checked DMH	Approved JHB
--------------------------	------------------	--------------	--------------	----------------	-----------------



Product Specifications:
Pre-Rinse Unit: 8" Deck Mount Mixing Faucet w/ Ceramic Cartridges, Add-On Faucet w/ 6" Swing Nozzle, 5SV Spray Valve, 6" Wall Bracket, In-Line Check Valves & 1/2" NPT Female Inlets

equip Foodservice Accessories
 2 Saddleback Cove, P.O. Box 1088
 Travelers Rest, South Carolina 29690
 Phone: 800.891.4808 Fax: 800.868.0084