



## CA31-ES16-CD-R

Transport Cabinet - Non Insulated



### Features:

- Clear door with magnetic latch handle
- Interlocking extruded side panels welded together
- 18" x 26" pans are lip-hung on 1 1/2" centers
- Standard with right hand hinging; left hand hinging available upon request

### Options:

- Push handle
- Sterno Option
- Perimeter or corner bumpers
- Solid aluminum door
- Hasp lock
- Additional caster options available



Manufacturing Material and Food Handling Equipment



**CA31-ES16-CD-R**  
 Transport Cabinet - Non Insulated

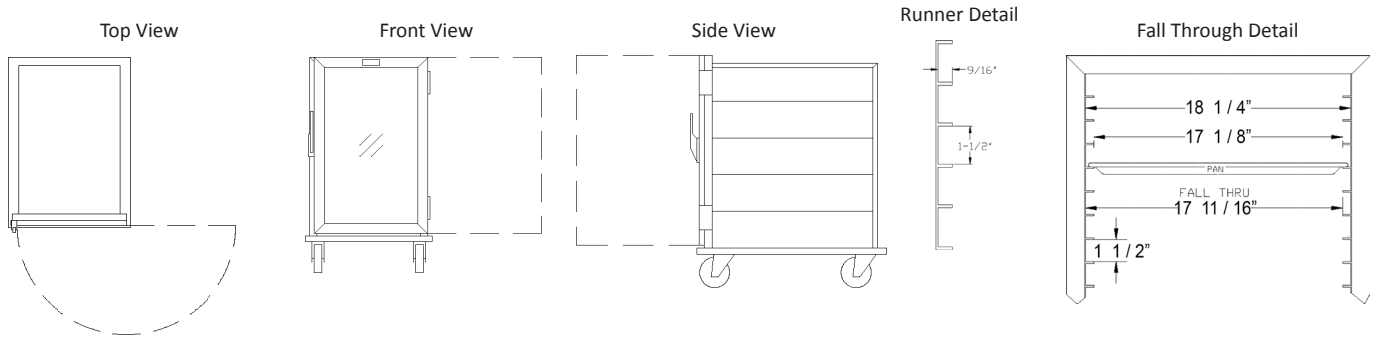

Lockwood Model No.	Pan			Exterior Dimensions			Inside Dimensions				Weight
	Angles	Capacity		Width	Depth	Height	Width	Depth	Height		
CA31-ES16-CD-R	Extruded Sides	16	IN	22 3/8	31 3/16	31 7/8	18 1/4	28 1/4	24 1/8	LBS	44
			CM	56.85	79.22	80.96	46.36	71.76	61.28	KG	19.96

\*\* Add 2" to width and depth with corner bumper option

**Cabinet Specifications:**

- Top & back panel: One piece 0.125" aluminum welded to extruded side panels and base
- Side panels: Extruded .070" aluminum panels; welded together.

**Base Specifications:**

- One piece .125" aluminum; formed construction
- Casters: (4) 5" x 1 1/4" High Tech grey swivel (2 w/brakes); load capacity 250 lbs each (113.4 kg); temp. range -45 ° / +180° F

**Door Specifications:**

- Frame: 7/8" x 1 3/4" extruded aluminum screwed and welded together
- Panel: .118" clear polycarbonate, fitted into door frame
- Latch: Magnetic type latch handle screwed to door frame
- Hinges: 4" stainless steel - opens 180°
- Gasket: Perimeter; fitted into frame extrusion, flexible PVC rubber

**Pan Support Specifications:**

- Extruded .070" aluminum

***Lockwood reserves the right to change materials and specifications without notice.***