

## CA39-PFIN-CD-R

Insulated Proofer / Hot Stor Cabinet

### Features:

- Digital thermometer
- Temperature adjustable to approximately 180° F
- Exterior mounted controls
- Easy to use heat unit with separate temperature and humidity controls
- Removable heat unit for easy maintenance and repair
- Blower fan and pan stop provide uniform heat distribution throughout cabinet
- Furnished with 7 pair of 5 1/2" universal pan supports
- Accommodates a wide range of pans and screens
- Will accommodate up to 13 pans on 1 1/2" centers
- Standard with right hand hinging; left hand hinging available upon request

### Options:

- 1 1/2" or 3 1/2" pan supports
- Solid insulated door
- Perimeter or corner bumpers
- Hasp lock
- Caster options available



Manufacturing Material and Food Handling Equipment



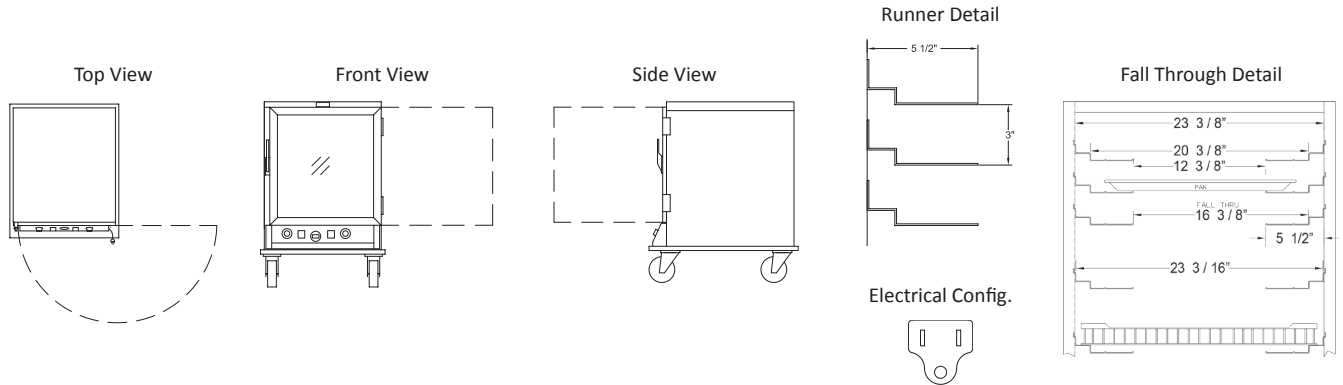

Lockwood Model No.	Pan			Exterior Dimensions			Inside Dimensions				Weight
	Angles	Capacity		Width	Depth	Height	Width	Depth	Height		
CA39-PFIN-CD-R	7 pair	13	IN	28 1/2	35	42 9/16	23 3/8	27 3/8	26 3/8	LBS	125
			CM	72.39	88.9	108.10	58.39	94.95	67.01	KG	56.70

\*\* Add 2" to width and depth with corner bumper option

**Cabinet Specifications:**

- Top: One piece .063" aluminum; riveted and welded to sides and back
- Side panels: Formed .090" aluminum; welded to base and top
- Back panel: .090" aluminum; welded and riveted to base and top

**Base Specifications:**

- One piece .125" aluminum; formed construction
- Casters: (4) 6" x 2" polyurethane swivel (2 w/brakes); load capacity 900 lbs each (408.23 kg); temp. range -45 ° / +180° F

**Door Specifications:**

- Frame: 7/8" x 1 3/4" extruded aluminum screwed and welded together
- Panel: .118" clear polycarbonate, fitted into door frame
- Latch: Magnetic type latch handle screwed to door frame
- Hinges: 4" stainless steel - opens 180°
- Gasket: Perimeter; fitted into frame extrusion, flexible PVC rubber

**Pan Support Specifications:**

- Extruded .085" aluminum; removable
- Adjustable on 1 1/2" centers

**Heat Unit Specifications:**

- Removable bottom mount proof / hold unit
- Body: Formed .063" aluminum
- Thermostat (holding): Mechanical, up to 195°
- Thermostat (humidity): Mechanical, up to 95%
- Indicator lights: Power, Proof, Hold modes
- Switches: (2) Rocker type with guards
- Heat Elements: (1) 1000 W, (1) 500 W internal; (1) 1000 W immersible external for proofing
- Blower Motor
- Thermometer
- Water Pan: 4.3 quart, 23 ga., 18/8 stainless steel

**Power Requirements:**

- 1500 Watts, 120 Volts, 60 Hz, Single Phase 15 Amp.
- Dedicated 15 Amp. service.

***Lockwood reserves the right to change materials and specifications without notice.***