

CA71-PFIN-CDD-R

Insulated Proofer / Hot Stor Cabinet

Features:

- Digital thermometer
- Temperature adjustable to approximately 180° F
- Exterior mounted controls
- Easy to use heat unit with separate temperature and humidity controls
- Removable heat unit for easy maintenance and repair
- Blower fan and pan stop provide uniform heat distribution throughout cabinet
- Furnished with 16 pair of 5 1/2" universal pan supports
- Accommodates a wide range of pans and screens
- Will accommodate up to 35 pans on 1 1/2" centers
- Integrated side handles
- Standard with right hand hinging; left hand hinging available upon request

Options:

- 1 1/2" or 3 1/2" pan supports
- Solid insulated door
- Full clear door
- Perimeter or corner bumpers
- Hasp lock
- Caster options available



Manufacturing Material and Food Handling Equipment





CA71-PFIN-CDD-R

Insulated Proofer / Hot Stor Cabinet

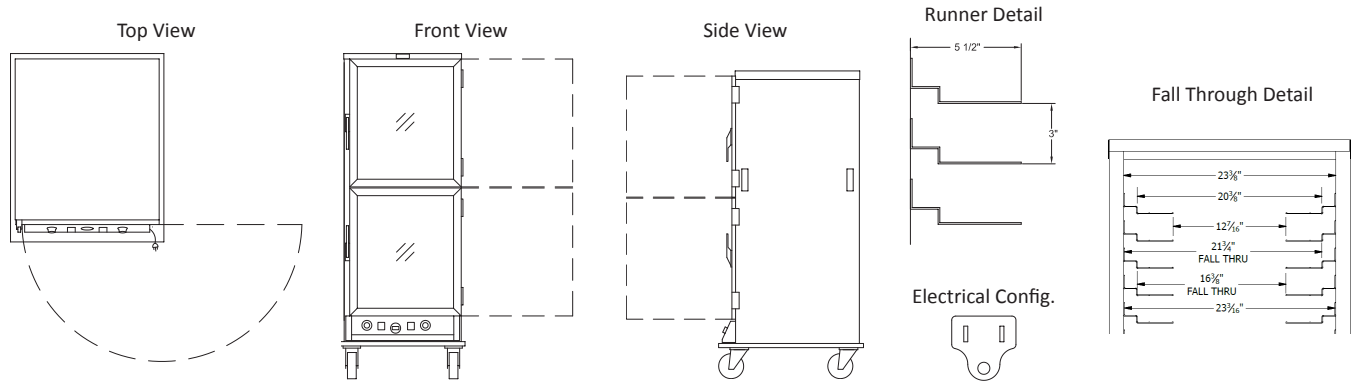

Lockwood Model No.	Pan			Exterior Dimensions			Inside Dimensions				Weight
	Angles	Capacity		Width	Depth	Height	Width	Depth	Height		
CA71-PFIN-CDD-R	16 pair	35	IN	28 1/2	35	74 1/2	23 3/8	27 3/8	58 3/8	LBS	201
			CM	72.39	88.9	189.23	59.39	94.95	148.29	KG	91.17

** Add 2" to width and depth with corner bumper option

Cabinet Specifications:

- Top: One piece .063" aluminum; riveted and welded to sides and back
- Side panels: Formed .090" aluminum; welded to base and top
- Back panel: .090" aluminum; welded and riveted to base and top

Base Specifications:

- One piece .125" aluminum; formed construction
- Casters: (4) 6" x 2" polyurethane swivel (2 w/brakes); load capacity 900 lbs each (408.23 kg); temp. range -45 ° / +180° F

Door Specifications:

- Frame: 7/8" x 1 3/4" extruded aluminum screwed and welded together
- Panel: .118" clear polycarbonate, fitted into door frame
- Latch: Magnetic type latch handle screwed to door frame
- Hinges: 4" stainless steel - opens 180°
- Gasket: Perimeter; fitted into frame extrusion, flexible PVC rubber

Pan Support Specifications:

- Extruded .085" aluminum; removable
- Adjustable on 1 1/2" centers

Heat Unit Specifications:

- Removable bottom mount proof / hold unit
- Body: Formed .063" aluminum
- Thermostat (holding): Mechanical, up to 195°
- Thermostat (humidity): Mechanical, up to 95%
- Indicator lights: Power, Proof, Hold modes
- Switches: (2) Rocker type with guards
- Heat Elements: (1) 1000 W, (1) 500 W internal; (1) 1000 W immersible external for proofing
- Blower Motor
- Thermometer
- Water Pan: 4.3 quart, 23 ga., 18/8 stainless steel

Power Requirements:

- 1500 Watts, 120 Volts, 60 Hz, Single Phase 15 Amp.
- Dedicated 15 Amp. service.

Lockwood reserves the right to change materials and specifications without notice.