

CA73-PF16-CDD-R

Economy Proofer with Removable Pan Supports

Features:

- In-Door Digital thermometer
- Temperature adjustable to approximately 160° F
- Interior mounted controls
- Easy to use heat unit with separate temperature and humidity controls
- Removable heat unit for easy maintenance and repair
- Blower fan and pan stop provide uniform heat distribution throughout cabinet
- Furnished with 16 pair of 1 1/2" pan supports on 3 1/4" centers
- Standard with right hand hinging; left

Options:

- 3 1/2" or 5 1/2" pan supports
- Full clear or solid aluminum door
- Solid aluminum Dutch Doors
- Perimeter or corner bumpers
- Hasp lock
- Caster options available



Manufacturing Material and Food Handling Equipment





CA73-PF16-CDD-R

Economy Proofer with Removable Pan Supports

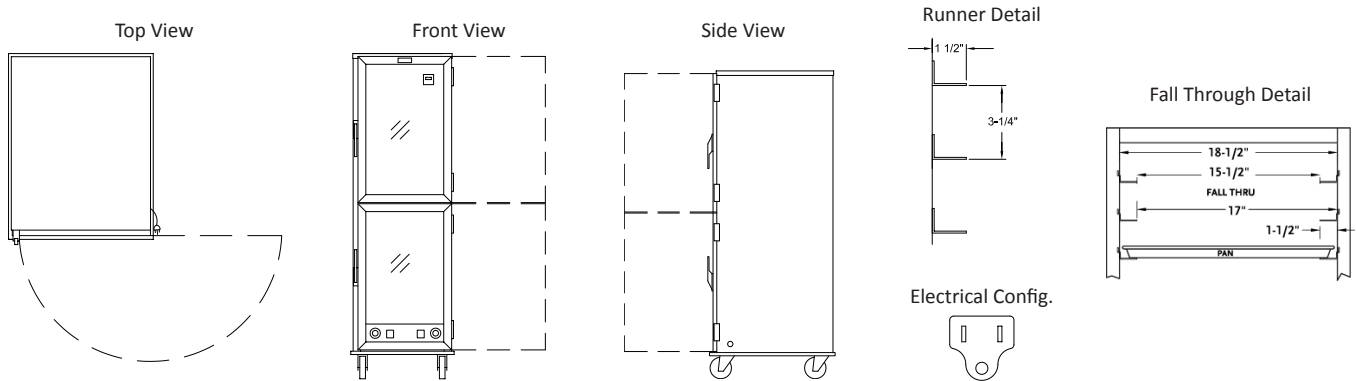

| Lockwood Model No. | Pan | | | Exterior Dimensions | | | Inside Dimensions | | | | Weight |
|--------------------|---------|----------|----|---------------------|--------|--------|-------------------|---------|--------|-----|--------|
| | Angles | Capacity | | Width | Depth | Height | Width | Depth | Height | | |
| CA73-PF16-CDD-R | 16 pair | 16 | IN | 22 7/8 | 29 3/8 | 72 1/4 | 18 1/2 | 26 1/16 | 59 1/4 | LBS | 131 |
| | | | CM | 58.12 | 74.63 | 183.52 | 46.99 | 66.20 | 150.50 | KG | 59.42 |

** Add 2" to width and depth with corner bumper option

Cabinet Specifications:

- Top: One piece .063" aluminum; riveted and welded to sides and back
- Side panels: Formed .090" aluminum; welded to base and top
- Back panel: .090" aluminum; welded and riveted to base and top

Base Specifications:

- One piece .125" aluminum; formed construction
- Casters: (4) 5" x 1 1/4" High Tech grey non-marking swivel (2 w/brakes); load capacity 250 lbs each (113.40 kg); temp. range -45°/ +180° F

Door Specifications:

- Frame: 7/8" x 1 3/4" extruded aluminum screwed and welded together
- Panel: .118" clear polycarbonate, fitted into door frame
- Latch: Magnetic type latch handle screwed to door frame
- Hinges: 4" stainless steel - opens 180°
- Gasket: Perimeter; fitted into frame extrusion, flexible PVC rubber

Pan Support Specifications:

- Extruded .080" aluminum; removable
- Adjustable on 3 1/4" centers

Heat Unit Specifications:

- Removable bottom mount proof / hold unit
- Body: Formed .063" aluminum
- Thermostat (holding): Mechanical, up to 195°
- Thermostat (humidity): Mechanical, up to 95%
- Indicator lights: Power, Proof, Hold modes
- Switches: (2) Rocker type with guards
- Heat Elements: (1) 1000 W, (1) 500 W internal; (1) 1000 W immersible external for proofing
- Blower Motor
- Thermometer
- Water Pan: 4.3 quart, 23 ga., 18/8 stainless steel

Power Requirements:

- 1500 Watts, 120 Volts, 60 Hz, Single Phase 15 Amp.
- Dedicated 15 Amp. service.

Lockwood reserves the right to change materials and specifications without notice.