



## Meal Delivery Carts

### Tall Profile, Single Door, 16 Tray Capacity

Models MDC1520T16

MDC1418T16

StoreSafe

#### Features & Benefits

- Durable carts designed to specifically meet the meal delivery needs of hospitals (acute care), long term care and correctional facilities.
- Designed to work with unitized pellet system, heat on demand base system or insulated trays.
- Single stack rail system handles two (2) trays per rail, eight (8) trays per compartment with a 5¼" (13,3 cm) clearance between rails.
- Serving capacity per cart:  
MDC1418T16 - 16 each 14" x 18" (36 x 46 cm) trays  
MDC1520T16 - 16 each 15" x 20" (38 x 51 cm) trays
- Rear mounted nylon roller menu clip keeps service instructions highly visible and easy to access.
- Durable, one-piece, molded polyethylene construction ensures long term durability and reliability. Molded bottom bumpers protect walls and furniture.
- Thick foamed-in place polyurethane insulation provides added structural strength and reduces noise while transporting.
- Has two (2) lightweight, non-rusting, aluminum louvered vents on the back of the cart for increased air circulation which optimizes food quality.
- Molded-in marine rail top offers an ergonomic work surface and keeps trays secure during service preparation. Marine rail is designed for use during staging service, not transport.
- Pressure molded ABS doors are lightweight, durable and open a full 270°. Can be securely positioned open onto the bottom catch rail for easy access during serving.
- Large stainless steel paddle latch is easy to open, rust free and can be removed and easily cleaned.
- Self-draining shelf and bottom in compartments facilitates easy cleaning.
- Molded-in rear handles make it easy to transport and maneuver.
- Four each 6" (15,24 cm) stainless steel casters, two (2) swivel with brake and two (2) fixed, enhance cart maneuverability and increase safety.
- Non electrical.
- No assembly required.
- Available in five (5) colors.

Item No. \_\_\_\_\_

Specifier Identification No. \_\_\_\_\_

Model No. \_\_\_\_\_

Quantity \_\_\_\_\_



MDC1418T16  
MDC1520T16



Two non-insulating, aluminum louvered vents on the back



Durable aluminum hinge pins & nylon clips can be easily removed for cleaning.

#### Approvals



# Meal Delivery Carts

## Tall Profile, Single Door, 16 Tray Capacity

Models MDC1520T16  
MDC1418T16

Item No. \_\_\_\_\_

Specifier Identification No. \_\_\_\_\_

Model No. \_\_\_\_\_

Quantity \_\_\_\_\_

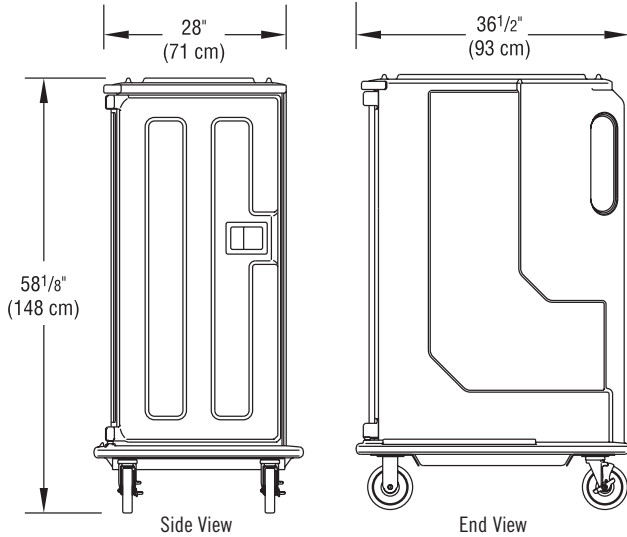

MDC1418T16

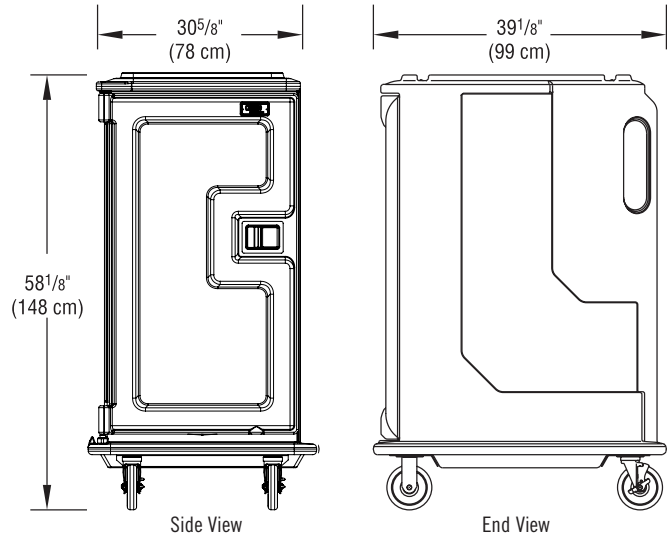

MDC1520T16

### Specifications

Dimension Tolerance: +/- 1/4" (0,64 cm)

CODE	TRAY CAPACITY PER COMPARTMENT	EXTERIOR DIMENSIONS W x D x H	Internal Dimensions W x D x H	CASE LB. (CUBE) CASE KG. (M <sup>3</sup> )
MDC1418T16	16 each 14" x 18" (36 x 46 cm)	28" x 36 1/2" x 58 1/8" (71 x 93 x 148 cm)	18 3/8" x 29 3/8" x 21 1/2" (46,7 x 74,6 x 54,6 cm)	143 (39,44) 64,9 (1,12)
MDC1520T16	16 each 15" x 20" (38 x 51 cm)	30 5/8" x 39 1/8" x 58 1/8" (78 x 99,4 x 148 cm)	20 3/8" x 30 1/2" x 21 1/2" (52,4 x 77,5 x 54,6 cm)	155 (45,87) 70,3 (1,3)

### Architect Specs

The non-electrical Meal Delivery Cart shall be a vertical access, single door Meal Delivery Cart, Model MDC1520T16 and MDC1418T16, manufactured by Cambro Mfg. Co., Huntington Beach, CA 92647, U.S.A. It shall be made of one-piece, seamless, double-wall, high-density, polyethylene and foam-injected polyurethane. It shall have a molded-in marine top rail. It shall have molded-in handles. It shall have two (2) lightweight, non-rusting, aluminum louvered vents on the back of the cart for increased air circulation which optimizes food quality. It shall have a pressure molded ABS door that opens a full 270° and can be securely positioned open onto the bottom catch rail. It shall have a single stack rail system that accommodates 2 trays per rail, 8 trays per compartment with a clearance of 5 1/4" (13,3 cm) between rails. It shall have a large stainless steel paddle latch that can be removed and easily cleaned. It shall have self-draining shelves. It shall have 4 each 6" (15,24 cm) stainless steel casters, 2 fixed and 2 swivel with brake. It shall have a rear mounted nylon roller menu clip. It shall require no assembly. It shall be available in 5 color combinations.

MDC1418T16 and MDC1520T16 Covered by U.S. Patent Des. 398,727

### Standard Colors

- Gray with Cream Color Door (180)
- Granite Gray with Cream Color Door (191)
- Granite Green with Cream Color Door (192)
- Granite Sand with Cream Color Door (194)
- Slate Blue with Cream Color Door (401)

### Approvals



© Cambro Manufacturing Company 5801 Skylab Road, Huntington Beach, California 92647-2056-U.S.A.  
Telephone 714 848 1555 Toll Free 800 854 7631 Customer Service 800 833 3003

D081420w