

Champion®

The Dishwashing Machine Specialists

Project _____
 Item No. _____
 Quantity _____

UL-130 UNDERCOUNTER

STANDARD FEATURES

- **Wash Refresh™** – Automatically drains the water for the next cycle, ensuring heavily soiled items are always sanitized with new wash water
- Pumped drain
- **StemSure™** – Soft start to protect glasses and dishes from chipping and breaking
- Door safety switch
- Low-water tank heat protection
- Built-in detergent, rinse-aid, and sanitizer dispensing pumps
- Wash pump, 1-Hp motor
- Electric tank heater
- Upper & lower interchangeable wash/rinse spray arms
- Top mounted controls
- Stainless steel top and side panels
- Single phase connection
- Stainless steel construction
- 115V power cord
- One year parts and labor warranty

UL-130

Low Temperature
 Undercounter
 Dishwashing Machine



NEW!



Photo is for general visual representation only. Please refer to specifications for the latest detailed product information.

OPTIONS & ACCESSORIES

- 1-RDT Dish Table** Durable, heavy-gauge stainless steel dish table with sink, stand-pipe drain, removable scrap screen holder, drain-board, backsplash and lower storage cabinet. Sprayhose is optional. See 1-RDT catalog sheet) Specify right hand or left hand sink.
- Additional Dish Racks**
- 17" Stand**
Stainless Steel
- 6" Leg Stand**
- 1" Roller Kit (includes 4 casters)**

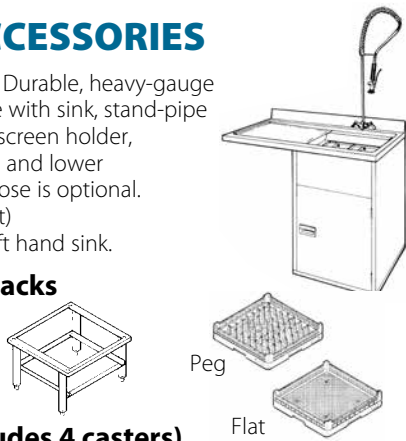

SPECIFIER STATEMENT

Specified unit will be Champion model UL-130 undercounter low temperature dishwashing machine with built-in detergent, rinse-aid, and sanitizer dispensing pumps.

Features 141 second total cycle, 1 Hp pump motor, fill and dump, pumped drain. Constructed of stainless steel.

1 year parts and labor warranty.

Champion Industries, Inc.
 3765 Champion Blvd, NC 27105
 Tel: 336/661-1556 Fax: 336/661-1979
www.championindustries.com

UL-130

Low Temperature
Undercounter
Dishwashing Machine

Champion[®]
The Dishwashing Machine Specialists

Dimensions shown in inches and [millimeters]

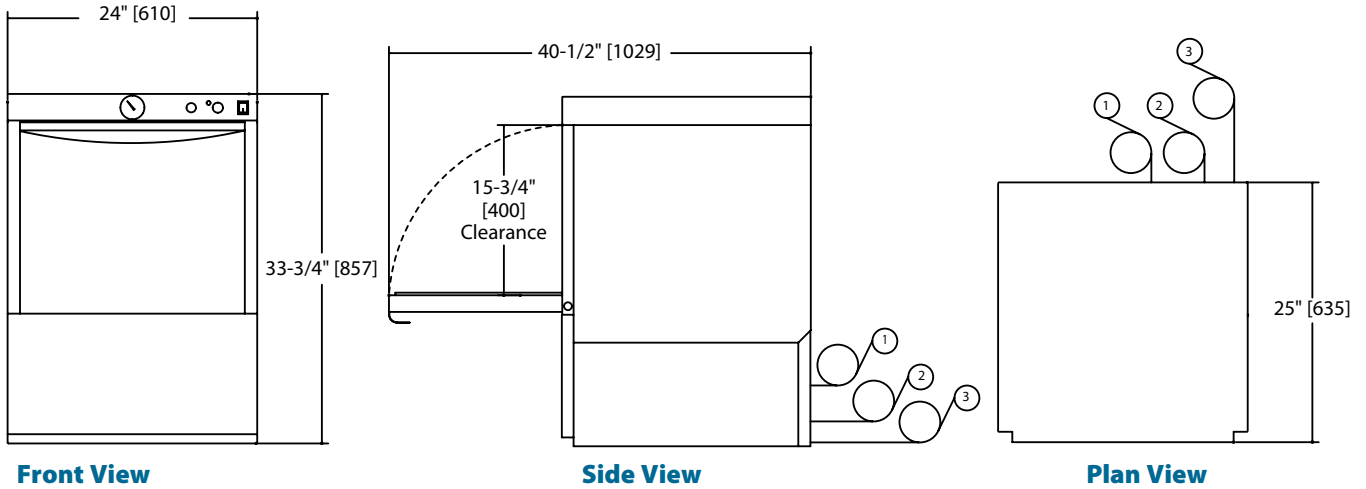

Utilities	
1 Electrical	115/60/1; 12-amp draw; to be fused at 15 amp. 4 ft. plug-in cord supplied.
2 Water connection	120°F minimum hot water connection (140°F recommended) 6 ft. long, 1/2" I.D. flexible fill hose with 3/4" hose connector. Flow pressure: 25-95 psi.
3 Pumped Drain	5/8" I.D. flexible reinforced hose, 6 ft. long. Max. drain flow 15 US gpm. Max. drain height 3 ft.

	Uncrated	Crated
Height*	33-3/4"	39-1/2"
Width	24"	25"
Depth	25"	25-1/2"
Ship Wt. lbs/kg	153	173

Warning Plumbing and electrical connections should be made by qualified personnel who will observe all the applicable plumbing, sanitary and safety codes and the National Electrical Code.

Due to an ongoing value analysis program at Champion, specifications contained in this catalog are subject to change without notice.

Champion Industries, Inc.,
3765 Champion Blvd., NC 27105
336/661-1556 • Fax: 336/661-1979
ChampionIndustries.com

SPECIFICATIONS

Capacity	Racks per hr.	25
Motor horsepower	Wash	1
Water consumption	U.S. Gal. per hr. (Max. use)	32
	U.S. Gal. per rack	1.5
Temperatures °F	Wash	120°F Min (140°F recommended)
	Rinse	120°F Min (140°F recommended)
Heating	Tank heat, electric (kW)	.75
Time cycle in seconds	Wash	90
	Rinse	26
	Drain/fill	25
	Total cycle	141
Standard 20" x 20" rack complement	Dish	1
	Open	1