

Champion®

The Dishwashing Machine Specialists

Project _____
Item No. _____
Quantity _____

CG GLASSWASHER

CG

Rotary Type Series
Fully Automatic
Glasswashing Machine

STANDARD FEATURES

- **NEW** 12" glass clearance accepts taller stemware
- **NEW** internal upper drain screen for improved filtration and ease of cleaning
- **NEW** Self flushing wash chamber reduces maintenance
- Reduced water usage
- Improved shut off mechanism
- Three pump injection system for precise chemical dispensing
- Upper and lower wash and rinse arms produce sparkling clean glasses every time
- Double walled construction for quieter operation.
- Cool final rinse water provides a cool glass ready for immediate use
- An off-the-floor shelf provides storage for three, 1-gallon containers
- Polypropylene conveyor virtually eliminates chipping of fine stemware
- Drain tray and waste collector (CG-71)



Photo is for general visual representation only. Please refer to specifications for the latest detailed product information.



SPECIFIER STATEMENT

Specified unit will be Champion model CG Rotary Type, fully automatic glasswasher.

Unit will have detergent pump, sanitizer pump and rinse aid pump, standard upper and lower wash/rinse arms, wash tank heater, cold water final rinse, polypropylene conveyor, splash curtains, double-walled construction, storage space for three 1-gallon containers.

1 year parts and labor warranty.

OPTIONS & ACCESSORIES

- Casters; set of four – 2 locking, 2 regular
- Hand sink and wet waste receiver (CG46C)
- Wash down hose

Champion Industries, Inc.
3765 Champion Blvd., Winston-Salem, NC 27105
Tel: 336/661-1556 Fax: 336/661-1979
www.championindustries.com

Dimensions shown in inches and [millimeters]

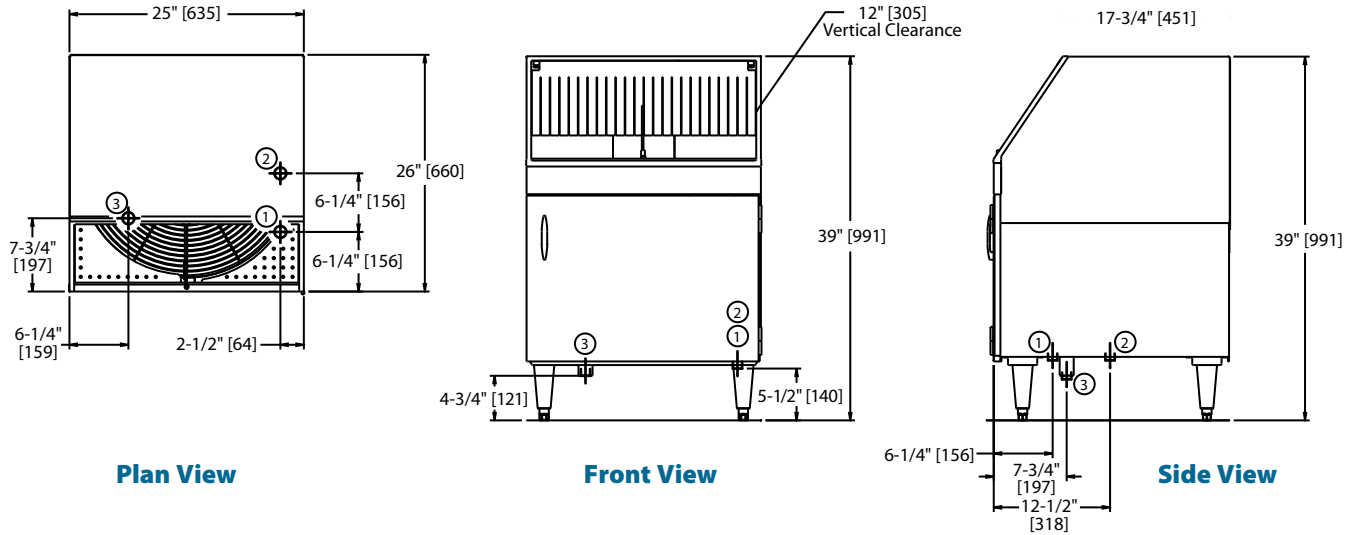

Utilities

	*Electrical 208 - 230/60/1, 15 amp
1	Hot water 1/2" IPS. Flow pressure 25-95 psi
2	Cold water 1/2" IPS. Flow pressure 25-95 psi
3	Drain 1-1/2" tailpiece. Connect to drain size according to local plumbing code.

*** NOTE:** CG models supplied with 6 ft. plug-in cord (NEMA 6-15P).

Warning: Plumbing and electrical connections should be made by qualified personnel who will observe all the applicable plumbing, sanitary and safety codes.

	Uncrated	Crated
Height	39"	46-1/2"
Width	25-1/4"	27"
Depth	26"	27-1/2"
Ship Wt. lbs/kg	156	176
* Adjustable foot height - 1-1/4"		

SPECIFICATIONS

Capacity (hr.)	2-1/2" glasses/hr.	1200
Conveyor Movement	CG	Clockwise
Water consumption	Cold Water (approx.)	2.5 gpm
	Hot Water (initial fill)	3 gpm
	(Max. use – approx. 10 gph)	
Temperatures °F	Inlet water (hot)	140-160
	Inlet water (cold)	75
Heating	Tank heat, electric, (kW)	3
Clearance	Through machine (inches)	12

Due to an ongoing value analysis program at Champion, specifications contained in this catalog are subject to change without notice.

Champion Industries, Inc.,
3765 Champion Blvd., NC 27105
336/661-1556 • Fax: 336/661-1979
ChampionIndustries.com