

Champion®

The Dishwashing Machine Specialists

Project _____
Item No. _____
Quantity _____

DH2000 DOOR-TYPE

STANDARD FEATURES

- **NEW** Factory authorized startup
- **ENERGY STAR®** Qualified
- **NEW Exclusive** Field convertible to single or three phase, 208 or 240 volt, corner or straight through operation
- Built-in booster configured for 70° Rise
- Rinse Sentry – ensures 180°F final rinse
- Auto start – starts unit when doors are closed
- High temperature
- Single point connection
- High efficiency 1 HP pump
- 55 racks per hour
- Self draining pump
- Automatic tank fill
- Detergent/chemical connections
- Interchangeable upper and lower arm
- Top mounted splash proof controls
- Automatic drain valve
- Vent fan control
- Pressure regulating valve
- Low water tank heat protection

DH2000

High Temperature
Door-type
Dishwashing Machine



Photo is for general visual representation only. Please refer to specifications for the latest detailed product information.



OPTIONS & ACCESSORIES

- Drain Tempering Kit
- Side Panels
- NEW** Champion ION scale prevention system

SPECIFIER STATEMENT

Specified unit will be Champion model DH2000 high temperature door-type dishwashing machine.

Features top mounted splash proof controls, Rinse Sentry, Auto start, interchangeable stainless steel wash and rinse arms, 55 racks/hr., .90 US gals/rack.

1 year parts and labor warranty.

Champion Industries, Inc.
3765 Champion Blvd., Winston-Salem, NC 27105
Tel: 336/661-1556 Fax: 336/661-1979
www.championindustries.com

DH2000

High Temperature
Door-type
Dishwashing Machine

Shipping weight crated: 300 lbs.

Champion®

The Dishwashing Machine Specialists

Dimensions shown in inches

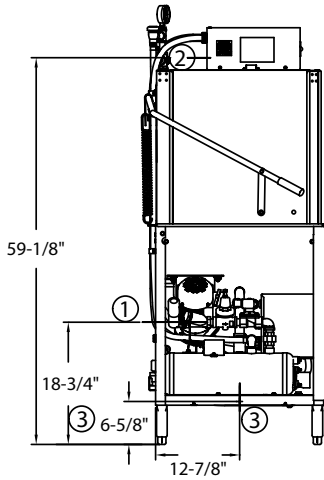

Side View

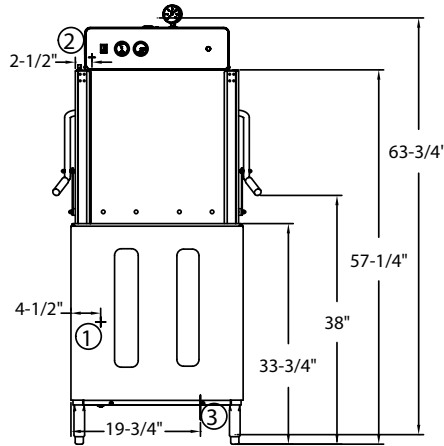

Front View

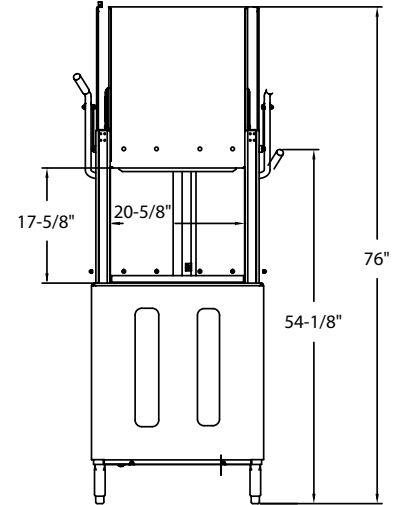

Door Clearance

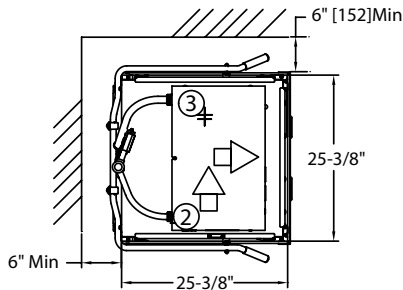

Corner Configuration

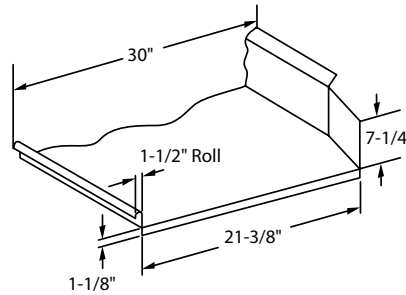

Typical Table Construction

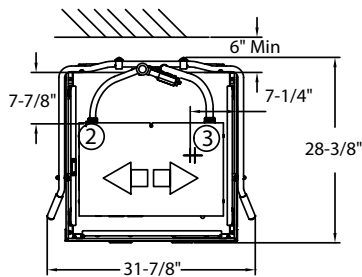

Straight Through

SPECIFICATIONS

Capacities

Racks per hr. (NSF rated)	55
Wash tank (gal.)	9.5

Motor horsepower

1 HP

Water consumption

Gal. per hr. (max. use)	49.5
Gal. per rack	0.9

Temperature °F

Wash	150
Rinse	180

Heating

Tank heat, electric	5.2 kW
Electric Booster	7.5 kW

Time cycle in seconds

Wash	40
Dwell	1
Rinse	12
Sanitary Dwell	7
Total cycle	60

Warning: Plumbing, electrical connections should be made by qualified personnel who will observe all the applicable plumbing, sanitary and safety codes and the National Electrical Code.

Utilities

1 Water	3/4" NPT Flow pressure 20-25 PSI Hot water 140°F (82°C)
2 Electrical 70° Booster	A. 208-220/60/1 (See Box) B. 208-220/60/3 (See Box)
3 Drain	A. 2" OD Connection Gravity flow, 15 GRM max flow

Machine and Electric 40°F/70°F OR 70°F Rise Booster

Voltage	Rated Amps	Min. Supply Ckt. Conductor Ampacity	Max. Overcurrent Protective Device
208/60/1	65	80	80
240/60/1	75	80	80
208/60/3	40	50	50
240/60/3	45	50	50

Due to an ongoing value analysis program at Champion, specifications contained in this catalog are subject to change without notice.

Champion Industries, Inc.,
3765 Champion Blvd., NC 27105
336/661-1556 • Fax: 336/661-1979
ChampionIndustries.com

an Ali Group Company



The Spirit of Excellence