

FLOOR TYPE, LEVER TILT ELECTRIC KETTLES

TILTING, "SPASH PROOF SERIES", SELF-CONTAINED
23 STEAM JACKETED, 20 GALLONS (80 LITERS)

Cleveland Standard Features

- Manual tilting, balanced design
- Self-contained, easily installed - needs only an electrical hook-up
- Steam jacket filled with treated water, venting and/or refilling is not required
- Accurate, consistent solid state temperature controls (mechanical thermostat not as accurate) - less than $\pm 1^{\circ}\text{C}$ variance (ideal for simmering). Operating temperature range from 145° - 260°F (63°C - 127°C)
Control panel includes:
 - LED indicator for heat cycle • LED indicator for low water
 - Power ON/OFF switch • Adjustable temperature control dial
- Water resistant controls, splash-proof construction
- Large pouring lip for high capacity and chunky products
- Re-inforced rolled rim design prevents damage to kettle rim, eliminates "bar rim designs"
- Welded-in heating elements, (holds vacuum better, won't leak or loose water)
- Easily cleaned: kettle and all exterior surfaces are of type 304 stainless steel with an #4 finish
- Rear mounted easy access pressure gauge and pressure relief valve to prevent tampering. Color coded easy to read pressure gauge with "green" and "vent air zone"
- 50 psi steam jacket rating for higher cooking temperatures
- 50 psi safety valve
- Solid state water level control (no sight glass gauge to break or leak)
- Splash proof element cover with a double gasket seal
- 6" level adjustable feet
- Standard voltage is 208-240 volts, 60 Hz, 3-phase, 3-wire. Field rewirable for single-phase, 2-wire systems
- Typical approvals include UL., CSA, CE, NSF and ASME

Options & Accessories

- Lift-off Cover (CL20)
- Double pantry faucet with swing spout and mounting bracket (DPK & FBKT)
- Voltage other than standard (VOS)
- Type 316 Stainless Steel Kettle interior for high acid food products (316)
- Food Strainer (FS)
- Basket Strainer (BS-)
- Single pantry faucet with swing spout (SPK)
- High Wattage Operation (HW) (see back page)

MODEL: KET-20-T



Short Form Specifications

Shall be CLEVELAND, Electric, self-contained Kettle, Model KEL-20-T; 20 gallons, tilting, ____ KW, ____ volt, ____ Hz, ____ - phase, 23 jacketed type. Type 304 Stainless Steel kettle and supports. Rated 50 psi with Safety Valve, Permanently filled Steam Jacket, Splash Proof Solid State Temperature ($\pm 1^{\circ}\text{C}$) and Safety Control System in plug-in Module including L.E.D. indicators. (Optional Lift-Off Cover)

- Kettle Accessory Kit (KAK)
 - Clean-up Brush (CB)
 - 36" Kettle Whip (KW)
 - Draw-off Brush (DB)
 - Measuring Strip (MS)
 - Kettle Markings (KM)
 - Protective Control Panel (PCE)
 - Optional Sliding Drain Drawer
- 36" Kettle Paddle (KP)
- 36" Kettle Brush (KB)
- 24 oz. Ladle (KL)

- CAPACITIES: (in 4 oz. servings, other sizes may be calculated)
20 Gallon / 80 liters 704 servings

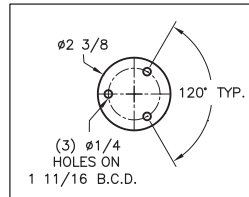
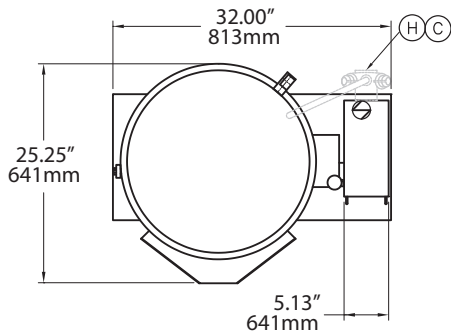
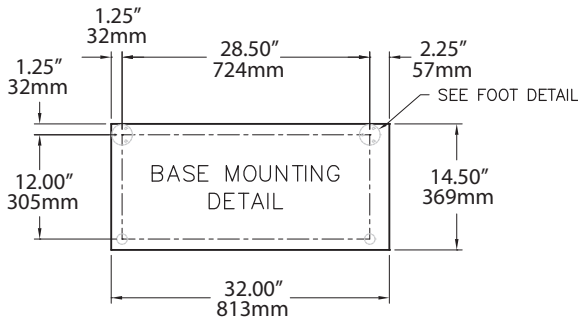

FOOT DETAIL

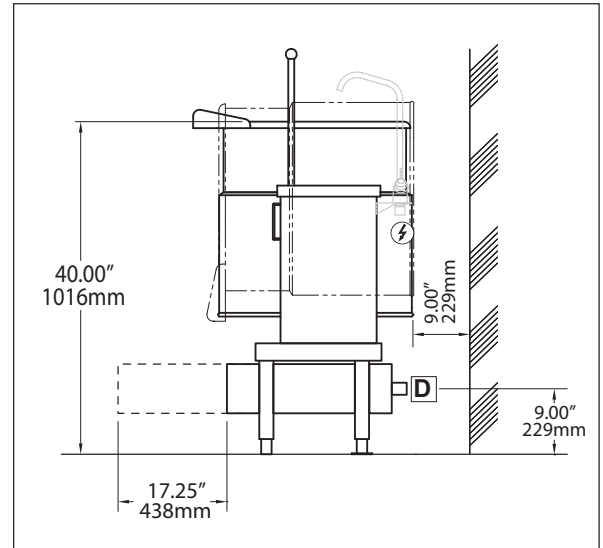

DIMENSIONS FOR UNITS WITH OPTIONAL SLIDING DRAIN DRAWER

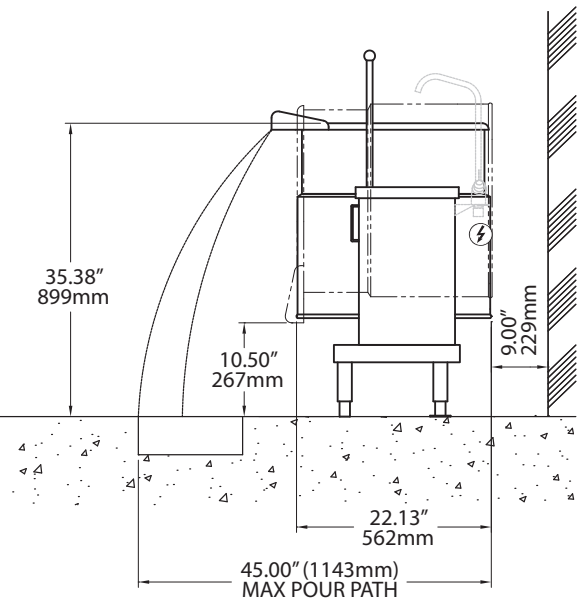
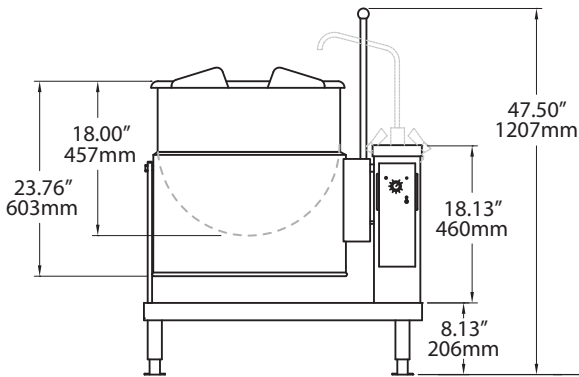

ELECTRICAL

Std/High Wattage	Supply Voltage	Phase	Wires	Total Wattage	Supply Amps	Wire Size	Std/High Wattage	Supply Voltage	Phase	Wires	Total Wattage	Supply Amps	Wire Size
S	200-208	1	2	12268	59.0	4	H	200-208	1	2	14721	70.8	3
S	200-208	3	3	12268	34.1	8	H	200-208	3	3	14721	40.9	6
S	220-240	1	2	16333	68.1	4	H	220-240	1	2	19599	81.7	3
S	220-240	3	3	16333	39.3	6	H	220-240	3	3	19599	47.1	6
S	380-415	1	2	15072	36.2	8	H	380-415	1	2	18087	43.5	6
S	380-415	3	3	15072	20.9	10	H	380-415	3	3	18087	25.1	8
S	440	1	2	13724	31.2	8	H	440	1	2	16469	37.4	6
S	440	3	3	13724	18.0	10	H	440	3	3	16469	21.6	10
S	440-480	1	2	16333	34.0	8	H	440-480	1	2	19599	40.8	6
S	440-480	3	3	16333	19.6	10	H	440-480	3	3	19599	23.6	10

WATER

3/8" O.D. copper tube or 1/2" N.P.T. pipe.

When ordered with optional faucet.

DRAIN

1/2" N.P.T. pipe (for optional sliding drain drawer).

CLEARANCE

RIGHT = 0", LEFT = 0"
REAR = 6" (152mm)

SHIPPING WEIGHT:

190 lbs. (86 kg.)

NOTES:

Cleveland Range reserves right of design improvement or modification, as warranted.
Many regional, state and local codes exist and it is the responsibility of the owner and installer to comply with the codes.
Cleveland Range equipment is built to comply with applicable standards for manufacturers. Included among those approval agencies are U.L., NSF, CGA, CSA, ETL and others.