



## Chemical Sanitizing Glasswasher

### FEATURES:

- **NEW** Noise Suppression Technology (NST).
- 30 racks / 120 covers per hour.
- Economical to operate. Uses only 1.7 gallons of water per cycle.
- All stainless steel construction assures long life and years of trouble-free operation.
- Unique spray arm system features upper and lower stainless steel wash arms with reinforced end caps.
- Double skin stainless steel provides consistent heating and a quiet operation.
- Built-in chemical pumps assure proper chemical usage.
- Delimiting system.
- Pumped drain allows for flexible installation. Requires no floor drain.
- Pump purging system improves results by eliminating soil and chemical carryover during rinse cycle.
- Water inlet comes with built-in strainer, prevents debris from clogging the water valve.
- 4" legs.
- Dishmachine comes with 2 dishracks, (1) peg and (1) flat.
- Large 11" door clearance to accommodate all size glasses.
- Sustainer Heater.

### Available Options

- Sanitizer Alarm
- CMA Temp-Sure™ (Self contained 12kW heater)
- 48" Undercounter Dishtable
- Pedestal
- 6" legs



**The New L-1C (NST) Low Temperature Glasswasher**  
Introducing CMA's "Noise Suppression Technology", combining sophisticated pump engineering, double wall construction, and sound deadening materials has reduced the noise output 50%, without sacrificing horse power or pump pressure. This is the ideal "behind the bar" glasswasher, providing outstanding results, economical to operate, and quiet operation. This glasswasher utilizes a recirculating wash system followed by a fresh water chemical sanitizing rinse. The "built-in" chemical dispensing system is programmable to provide precise chemical dosage per cycle.





## Chemical Sanitizing Glasswasher

### WARNINGS:

- Plumbing connections must be made by a qualified service company who will comply with all available Federal, State, and Local Health, Plumbing and Safety codes.
- CMA recommends utilizing a water softening system to maintain water hardness measurements of 3.5 gpg (grains per gallon) or less. This will assure maximum results and optimum operation of the dishmachine.

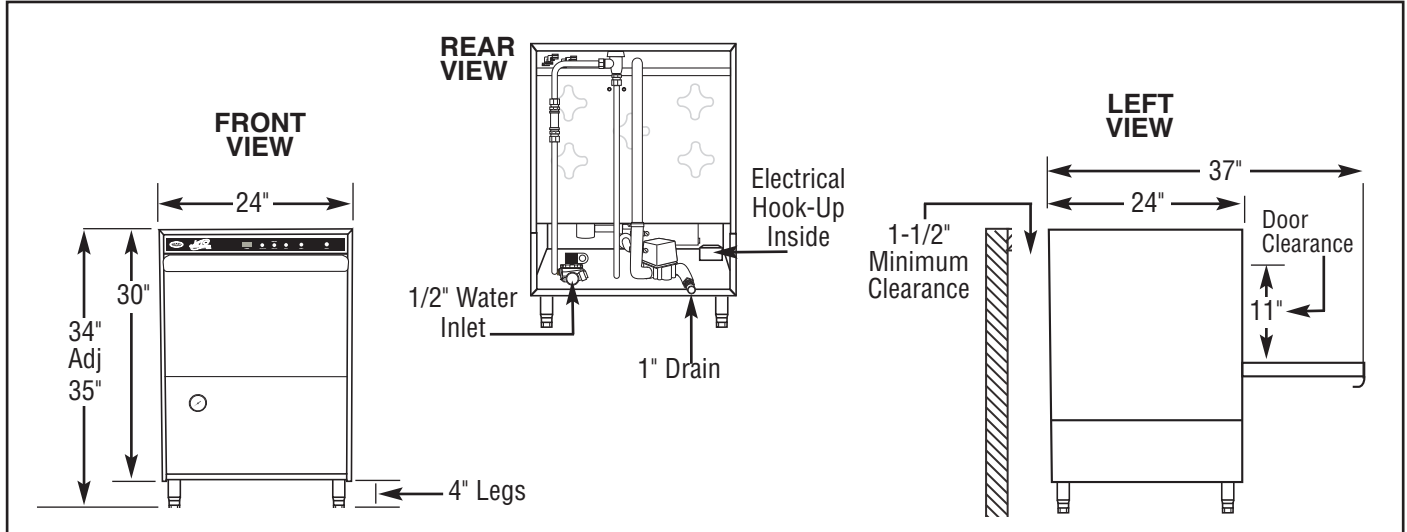

### Specifications:

MODEL L-1C	USA	METRIC	USA	METRIC
<b>OPERATING CAPACITY</b>				
RACKS PER HOUR (NSF RATED)	30	30		
<b>OPERATING CYCLE</b>				
WASH TIME-SEC	58	58		
RINSE TIME-SEC	32	32		
DWELL/PURGE-SEC	30	30		
TOTAL CYCLE TIME	2 MIN	2 MIN		
WASH TANK CAPACITY	1.7 GAL.	(6.43 L)		
WASH PUMP CAPACITY	35 GPM	(132 LPM)		
<b>OPERATING TEMPERATURE</b>				
REQUIRED	120°F	(49°C)		
RECOMMENDED	140°F	(60°C)		
<b>WATER CONSUMPTION</b>				
PER RACK	1.7 GAL.	(6.43 L)		
PER HOUR	34 GPH	(129 LPH)		
WATER INLET	1/2"	(1.27cm)		
DRAIN	1"	(2.54cm)		
<b>WASH PUMP MOTORS HP</b>			1	1
<b>DIMENSIONS</b>				
DEPTH	24"	(61cm)		
WIDTH	24"	(61cm)		
HEIGHT	34"-35"	(86.3-88.9 cm)		
MAXIMUM CLEARANCE				
HEIGHT FOR GLASSES	11"	(28cm)		
<b>STANDARD DISHRACK</b>			1	1
DIMENSIONS			19-3/4"X19-3/4"	(50X50cm)
<b>ELECTRICAL RATING</b>			<b>VOLTS</b>	<b>AMPS</b>
			115	11
<b>APPROXIMATE SHIPPING WEIGHT</b>			203#	(92kg)
<b>SHIPPING DIMENSIONS</b>			PALLET & BOX @ 29" X 28" X 38"	

### Summary Specifications: Model L-1C

CMA model L-1C, low temperature, undercounter, chemical sanitizing, commercial glasswasher meets NSF, UL and CUL sanitation and construction standards WITHOUT the use of BOOSTER or TANK HEATERS. The model L-1C is constructed entirely of stainless steel. Automatically washes, rinses and sanitizes food service utensils in standard 19-3/4"X19-3/4" racks. This model comes standard with upper and lower stainless steel wash arms. The L-1C incorporates a pump purging system that improves results by eliminating soil and chemical carryover during rinse cycle.

### New Innovative Noise Suppression Technology (NST)

**Advisory:** CMA does NOT endorse "Tankless On-Demand" water heaters for use on CMA Dishmachine products. CMA DOES endorse, and highly recommends, the standard "tank" style water heaters, sized properly to handle each particular facility with their water heating requirements.



CMA Dishmachines 12700 Knott Street Garden Grove, CA 92841 • 800-854-6417 • 714-898-8781 • Fax: 714-895-2141 • [www.cmadishmachines.com](http://www.cmadishmachines.com)

CMA reserves the right to modify specifications or discontinue models without prior notification.

PN: 10110.30

© 1-2018 CMA, Inc.

an Ali Group Company



The Spirit of Excellence