



UC65e

High Temp Undercounter Dishwasher And Glasswasher

FEATURES:



- **Energy Star Qualified.**
- 30 racks / 120 covers per hour.
- Fully automatic cycle for easy operation.
- Built-in detergent and rinse chemical pumps.
- Pump drain system allows for multiple installation applications including elevated drains.
- Safety Temp feature assures 180°F sanitizing rinse every cycle.
- Built-in 4kW booster heater.
- 2kW wash tank heater.
- Counter-balanced double skin door.
- Low 0.8 US gal. water usage per rack.
- Door safety switch, extended wash cycle switch.
- Stainless steel safety filters protect wash pump.
- Top mounted detergent and rinse-aid prime switches.
- Operator friendly, removable stainless steel wash and rinse arms allows for easy cleaning.
- (1) peg and (1) flat bottom rack supplied.

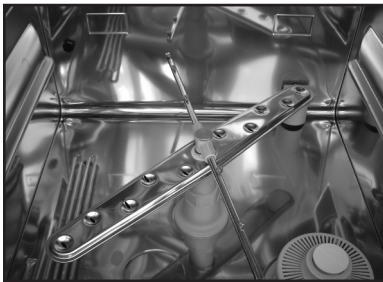

Upper and lower wash and rinse arms guarantee excellent results.



Uses standard 19-3/4" X 19-3/4" racks.

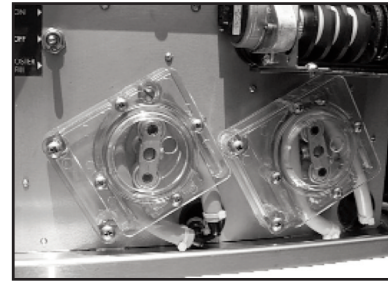

Built-in detergent and rinse chemical pumps.



Top mounted controls are easy to read and simple to operate.





UC65e

High Temp Undercounter
Dishwasher And
Glasswasher

WARNINGS:

- Plumbing connections must be made by a qualified service company who will comply with all available Federal, State, and Local Health, Plumbing and Safety codes.
- CMA recommends utilizing a water softening system to maintain water hardness measurements of 3.5 gpg (grains per gallon) or less. This will assure maximum results and optimum operation of the dishmachine.

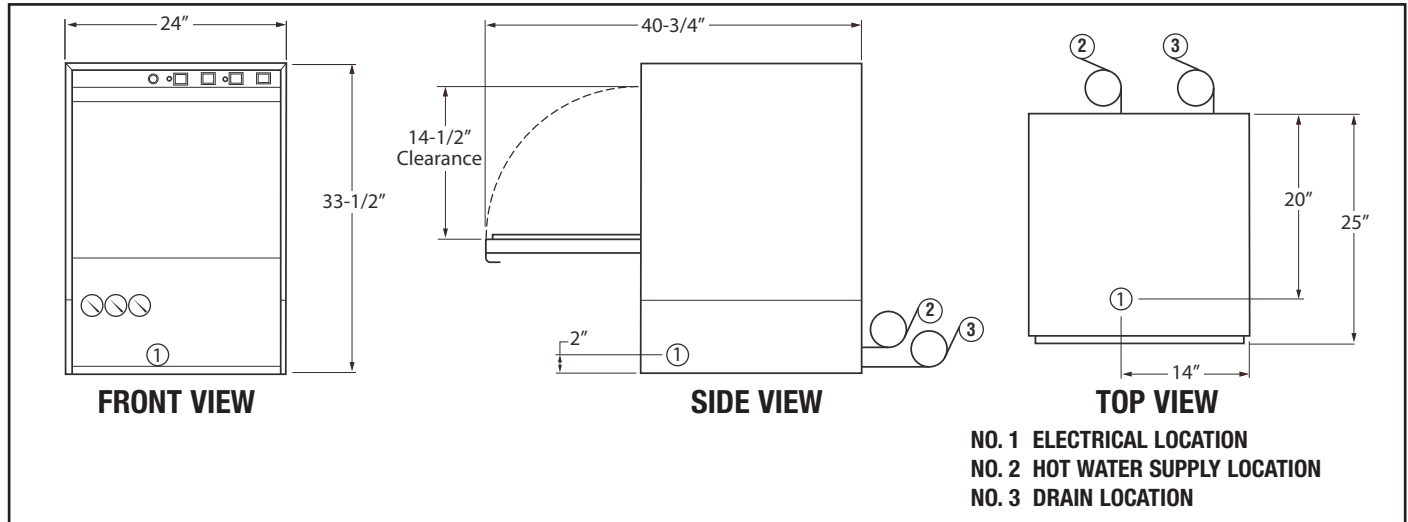

Specifications:

MODEL UC65e	USA	METRIC	USA	METRIC
WATER CONSUMPTION				
PER RACK	.8 GAL	(3.2 L)		
PER HOUR	20.4 GAL	(64 L)		
OPERATING CYCLE				
WASH TIME-SEC	100	100		
RINSE TIME-SEC	15	15		
DWELL-SEC	5	5		
TOTAL CYCLE-SEC	120	120		
OPERATING CAPACITY				
RACKS PER HOUR	30	30		
WATER REQUIREMENTS				
WATER CONNECTION (flexible hose)	140°F	(60°C)		
(supplied)	1/2" I.D.			
DRAIN CONNECTION (6 ft. flexible hose)	3/4" I.D.			
(supplied)				
FLOW PRESSURE	18-22 PSI	1.2-1.5 kg/cm ²		
CYCLE TEMPERATURES				
WASH (minimum)	150°F	(66°C)		
RINSE (minimum)	180°F	(82°C)		
FRAME DIMENSIONS				
DEPTH	25"	(63.5 cm)		
WIDTH	24"	(60.9 cm)		
HEIGHT	33-1/2"	(85.1 cm)		
MAX HEIGHT CLEARANCE FOR DISHES	14-1/2"	(36.8 cm)		
STANDARD DISHRACK				
DIMENSIONS	1	1		
	19-3/4" X 19-3/4"	(50X50CM)		
SHIPPING WEIGHT	148#	67KG)		
FRONT LEVELING FEET PROVIDED				
MOTOR	1HP			
HEATERS				
WASH TANK HEATER	2kW			
BOOSTER HEATER(40°F/22°C rise)	4kW			
ELECTRICAL RATING*	VOLTS	PHASE	AMPS	
	208	1	22	
	240	1	24	
*THIS SYSTEM REQUIRES THREE POWER WIRES WHICH INCLUDES A CURRENT CARRYING NEUTRAL. AN ADDITIONAL FOURTH WIRE MUST BE PROVIDED FOR MACHINE GROUND.				

Summary Specifications:

Specified unit will be a CMA model UC65e undercounter high temperature sanitizing dishmachine with built-in booster heater. Features include large 14-1/2" door opening clearance, standard liquid detergent and rinse-aid dispensing pumps, top, side and rear panels. Unit has standard pump drain, "Safe-T-Temp" feature to ensure proper 180°F final rinse temperature and stainless steel rinse arms with removable end caps for easy cleaning.

Advisory: CMA does NOT endorse "Tankless On-Demand" water heaters for use on CMA Dishmachine products. CMA DOES endorse, and highly recommends, the standard "tank" style water heaters, sized properly to handle each particular facility with their water heating requirements.



CMA MIZER
Registered Trademark

CMA Dishmachines 12700 Knott Street Garden Grove, CA 92841 • 800-854-6417 • 714-898-8781 • Fax: 714-895-2141 • www.cmadishmachines.com
CMA reserves the right to modify specifications or discontinue models without prior notification.

PN: 10901.00

© 11-2017 CMA, Inc.

an Ali Group Company



The Spirit of Excellence