

INSULATED STAINLESS STEEL HOT CABINET MODEL H-138-PS-1834D

FEATURES AND BENEFITS:

- Fully insulated hot cabinet keeps prepared foods at serving temperatures.
- Pass-thru design allows for access to preparation and serving areas.
- Powerful, yet efficient, 2000 Watt heating system maintains the right temperature to properly hold products. Heats up to 200°F (93°C).
- Standard solid state electronic control with large, clear, easy-to-read and operate LED digital display to ensure holding at precise food temperature
- Internal frame in body maintains structural rigidity.
- Stainless steel construction throughout for ease of cleaning. One piece extended base protects cabinet body.
- Smooth interior coved corners prevent food particles/grease buildup.
- Safety-conscious anti-microbial latches protect against spreading germs.
- Field reversible insulated Dutch doors on front and back prevent temperature loss. Silicone door gaskets for proper seal.
- Standard with right hand hinging; left hand hinging available upon request.
- High temperature ceramic magnetic latch for "easy open"; twist-lock catch secures door during transport.
- Recessed push/pull handles on both sides prevents damage to walls; allows easy maneuvering.
- Channel pan slides securely hold 18" x 26" pans on 1-1/2" centers without tipping.
- Heavy duty 5" swivel casters, two with brakes. Provides mobility when fully loaded.



H-138-PS-1834D



Standard solid state electronic control with large, clear, easy-to-read and operate LED digital display to ensure holding at precise food temperature

ACCESSORIES and OPTIONS

(Available at extra cost):

- Food Temperature Probe
- Tempered Glass Door Windows
- Key Lock Handle
- Lock Hasp
- Corner Bumpers
- Perimeter Bumper
- Floor Lock (for use with 5" casters)
- Various Caster Options
- 208 or 240 Volt Service

See page B-20 for accessory details.



H-138-PS-1834D

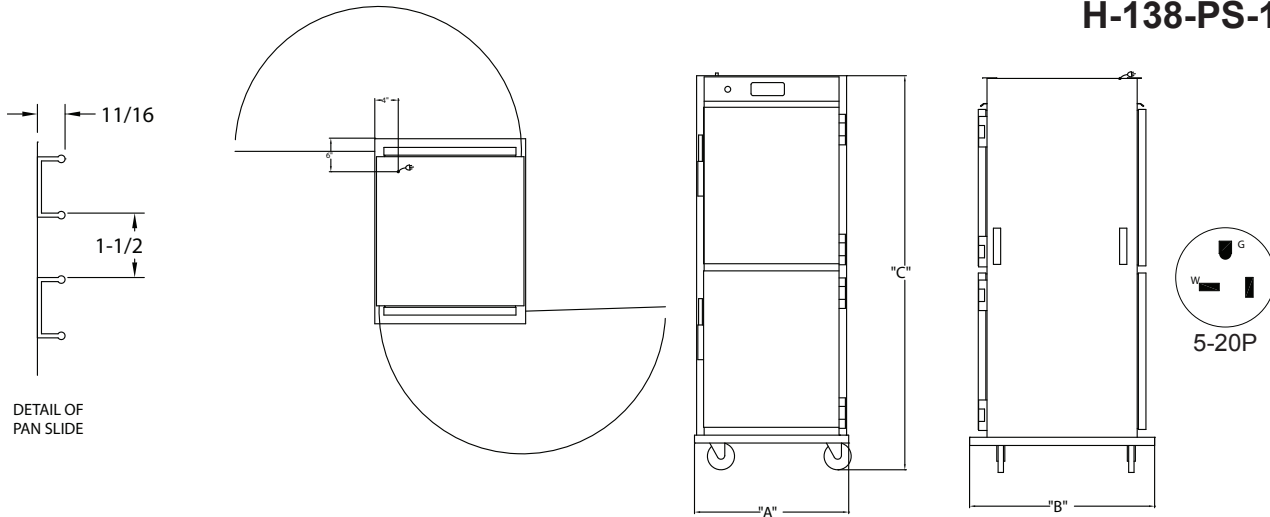

CRES COR MODEL NO.	PAN			DIM "A"	DIM "B"	DIM "C"	INSIDE DIMENSIONS			WEIGHT ACT.	
	CAP	SIZE		WIDTH	DEPTH	HEIGHT	WIDTH	DEPTH	HEIGHT		
H-138-PS-1834D	32	18 X 26	IN	28-3/4	34-5/8	73-1/2	18-1/16	26-7/8	58	LBS	272
		460 X 660	MM	730	880	1865	460	685	1475	KG	123

- NOTES: 1. Send sample pan or tray with order when using any that are not 18" x 26" pans with heavy beaded edges.
2. When ordering bumpers, add 2" to overall dimensions.



Gold indicates our Best Insulated Hot Cabinets with the best warranty in the industry.
3-Year Parts / 1-Year Labor.

CABINET:

- Body: 22 ga. stainless steel.
- Reinforcement: Internal framework of 18 ga. stainless steel.
- Insulation: Fiberglass, thermal conductivity (K factor) is .23 at 75°F. 1-1/2" in doors, top, base; 2" in sidewalls.
- Air tunnels: 22 ga. stainless steel; lift-out type, mounted on sides.
- Push/pull handles (4): 5" vertical; recessed.
- Interior coved corners.

BASE:

- One piece construction, .125 aluminum.
- Casters: 5" dia., swivel, modulus tires, 1-1/4 wide, load cap. 250 lbs. each, temp. range -45°/+180°F. Delrin bearings. Front casters equipped with brakes.

DUTCH DOORS:

- Field reversible.
- Formed 22 ga. stainless steel.
- Latches: Chrome plated zinc, high temperature ceramic magnetic type, mounted inboard.
- Transport Latches.
- Hinges: Heavy duty chrome plated zinc.
- Gaskets: Perimeter type, silicone.
- Pan stops: Embossed.

PAN SLIDES:

- Channels: Extruded aluminum, 11/16 x 1-1/2 x .100, riveted on 1-1/2" centers.

HOT UNIT COMPONENTS:

- Thermostat: Solid state digital display control, room ambient to 200°F (93°C).
- Switch: ON-OFF push button type.
- Power cord: Permanent, 10 ft., 12/3 ga.
- Heater: 1850 Watts.
- Blower motor.
- Vent Fan.
- Thermometer: Digital.

POWER REQUIREMENTS:

- 2000 Watts, 120 Volts, 60 Hz., single phase, 16 Amps., 20 Amp. service.

SHORT FORM SPECIFICATIONS

Cres Cor Insulated Hot Cabinet Model H-138-PS-1834D. Solid state electronic controlled time and temperature. Cabinet 22 ga. stainless steel; stainless steel internal frame. No-tip .100 aluminum channel slides for (32) 18" x 26" pans on 1-1/2" centers. Field reversible Dutch doors, 22 ga. stainless steel. Fiberglass insulation in sides 2"; doors, top, base 1-1/2". Interior coved corners. 2000 Watt, 120 Volt power unit. One piece insulated base, .125 aluminum. 5" swivel modulus casters, Delrin bearings. Load capacity 250 lbs. each. 3-Year Parts / 1-Year Labor warranty. Provide the following accessories: ____ ____ . NSF, CSA-US, CSA-C listed.



Scan QR code to view Spec Sheet, Operating Manual, Wiring Diagram or to call Customer Service.

If you need a QR reader visit your App Store on your Smartphone or Tablet.



5925 Heisley Road • Mentor, OH 44060-1833
Phone: 877/CRESCOR • Fax: 440/350-7267
www.crescor.com

© Crescent Metal Products, Inc. 2016 All rights reserved.

In line with its policy to continually improve its products, CRES COR reserves the right to change materials and specifications without notice.

Litho in U.S.A.