

General Information

Project Name: _____

Consultant: _____

Item #: _____

Model #: _____

Quantity: _____



Specifications

DL-2 Model Utensil/Can Washer and Sanitizer is constructed of 16GA type 300 series stainless steel which consists of a coved wash basin with 1" OD tubular equipment supports and fully integrated outer shell with a 12" high backsplash. Perforated scrap drawer collects solid waste for periodic disposal.

Faucet is T&S #B-1152 or equal, with flexible 44" long stainless steel hose and brush spray head mounted on top of backsplash. Double foot pedal valve is mounted on a stainless steel bracket and controls heavy-duty nozzle spray head with a 360 degree revolving cleaning pattern. Bottom drains to a 2" brass waste outlet. Entire unit is mounted on adjustable stainless steel legs.

Product Guide

IMC Utensil/Can Washer and Sanitizers are easily cleanable without the use of tools. All corners are covered, and all seams are fully welded and polished.

Compact design with multiple features is ideal for cleaning and washing all large and medium sized utensils and cans or pots. Faucet is used for pot filling or cleaning. Spray brush head helps loosen solid waste. Built-in nozzle spray head at the bottom provides a powerful cleaning cycle. Scrap tray is to be emptied and easily cleaned.

Options

- USH24** - 24" Utility Shelf
- USH36** - 36" Utility Shelf
- DLF** - Can Washer Faucet
- CWSD** - Scrap Drawer
- SBL** - Seismic Bolt Down Legs
- H72** - 72" Long Hose in Lieu of 44"
- SS12** - Side Splash 12" High (Per Side)





DRAWINGS

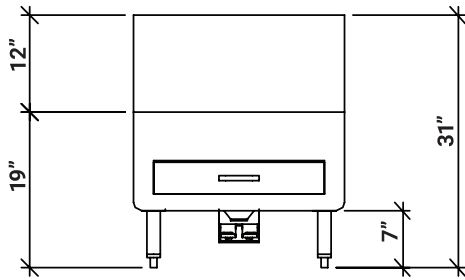

ELEVATION

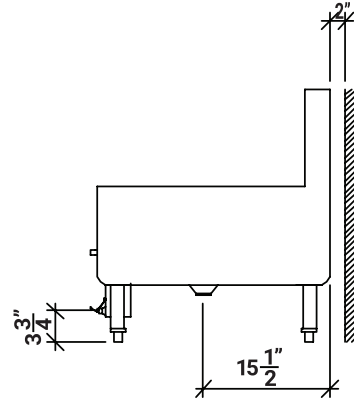

END

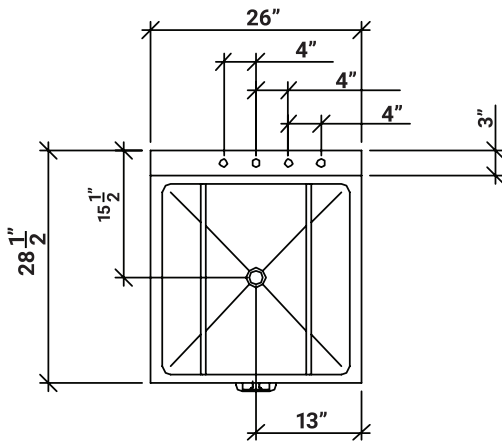

PLAN

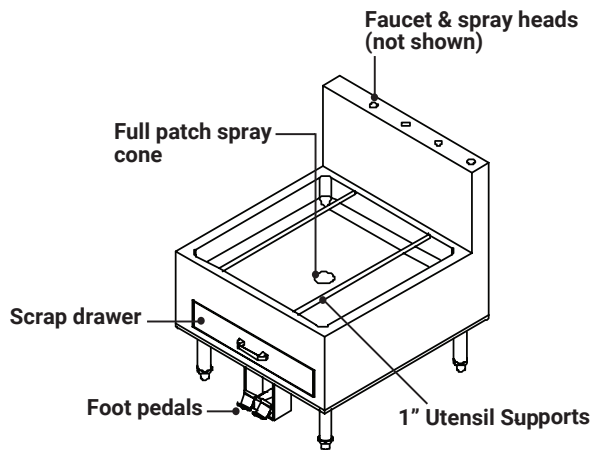

UTENSIL/CAN WASHER AND SANITIZER

Model	Size (W x L x H)
□ DL-2	28½" x 26" x 31"

Specifications subject to change without notice.

DL-2 40 0318