



www.doyon.qc.ca • www.nu-vu.com

## JAOP6

### OVEN/PROOFER COMBINATION

The JAOP series from Doyon is known worldwide for its unique JET AIR SYSTEM. The air moves in one direction, stops then moves the other way resulting in a bidirectional and gentle velocity air flow for exceptional baking results. This system will help you bake faster and more evenly without having to turn pans during baking time. The Jet Air fan system will save energy and labor costs.

The JAOP provides great flexibility in terms of range of products that can be baked or cooked. It features a programmable or manual one shot and constant pulse steam injection. To get the results you really want, we have added as standard a fan delay for those delicate products.

It's the easiest way to proof with an even air flow system, fully automatic humidity system for heat and moisture (no water pans to fill). It comes with heat and humidity controls.



JAOP6SL

### STANDARD FEATURES

#### OVEN

- Unique shot and pulse steam injection
- Jet Air exclusive reversing fan system
- Two speeds fan and fan delay switch
- Manual mode and user friendly EBake programmable control up to 99 recipes
- Digital temperature control up to 500°F
- Digital reminder timer
- USB Port
- Brightly lit, compact space saving unit
- Full view heat reflective thermal glass doors
- Fully insulated, completely sealed
- Energy efficient electric or gas heating
- Magnetic latches
- Door switch cutoff for fan blower
- 4 swivel casters (2 locking)
- Stainless steel inside and outside
- 3/4 HP motor
- 2 year parts 1 year labor limited warranty

#### PROOFER

- Temperature range from 90°F to 110°F (32°C to 43°C) with relative humidity up to 95%
- Manual Controls
- Automatic water fill
- Brightly lit
- Stainless steel inside and outside
- Magnetic door latches
- Separate heat and humidity controls
- Door drip pan
- Exclusive rust & scratch proof shelving

#### OPTIONS

- Water softener: PLF240
- Perforated nickel plated pizza decks
- High temperature gasket for baking over 400°F (205°F)
- Gas quick disconnect kit (4' (1220 mm) flexible hose, ball valve and securing device)



*Experience our top-of-the-line ovens today!*



5600 13th Street • Menominee, MI 49858 USA

Phone: 906-863-4401

E-mail: sales@nu-vu.com

Toll Free: 1-800-338-9886

www.doyon.qc.ca

Fax: 906-863-5889

www.nu-vu.com

## OVERALL DIMENSIONS

JAOP6 36 7/8" W X 48 1/8" D X 73" H

(937 mm X 1222 mm X 1854 mm)

JAOP6G 36 7/8" W X 53" D X 73" H

(937 mm X 1346 mm X 1854 mm)

JAOP6SL 38 3/8" W X 37 5/8" D X 73" H

(975 mm X 956 mm X 1854 mm)

## ELECTRICAL SYSTEM

### JAOP6 - JAOP6SL

#### 1 Phase:

208V - 64 A - 14 kW - 60 Hz - 2 wires + Ground

240V - 59 A - 14 kW - 60 Hz - 2 wires + Ground

#### 3 Phases:

208V - 46 A - 14 kW - 60 Hz - 3 wires + Ground

240V - 42 A - 14 kW - 60 Hz - 3 wires + Ground

*Other voltages available*

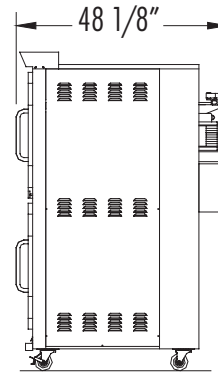

JAOP6  
Side

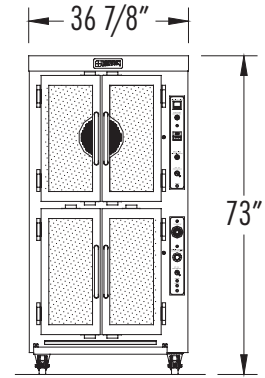

JAOP6  
Front

## GAS SYSTEM

### JAOP6G (Propane or natural)

BTU total: 65 000 BTU

#### 1 Phase:

208-240V - 17 A - 4 kW - 60 Hz - 2 wires + Ground

Gas Inlet: 1/2" NPT

Draft hood: 4" (102 mm)

Recommended gas pressure:

Propane gas: 11" W.C. Natural gas: 7" W.C.

## WATER INLET: 1/4" NPT

Minimum clearance from combustible material

1" (25 mm) side and back

4" (102 mm) on non combustible floor

12" (305 mm) top

**FINISH:** Stainless steel

## SHIPPING WEIGHT

JAOP6: 965 lb (438 kg) approximately

JAOP6G: 1135 lb (515 kg) approximately

JAOP6SL: 965 lb (438 kg) approximately

## CAPACITY

### JAOP6 - JAOP6G

#### Oven

Standard sheet pans 18" X 26" (457 mm X 660 mm) : 6 pans

#### Proofer

Standard sheet pans 18" X 26" (457 mm X 660 mm) : 18 pans

### JAOP6SL

#### Oven

Standard sheet pans 18" X 26" (457 mm X 660 mm) : 6 pans

#### Proofer

Standard sheet pans 18" X 26" (457 mm X 660 mm) : 9 pans

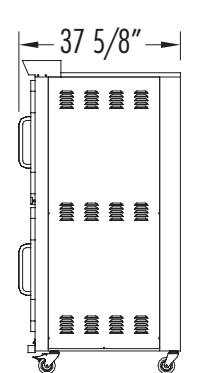

JAOP6SL  
Side

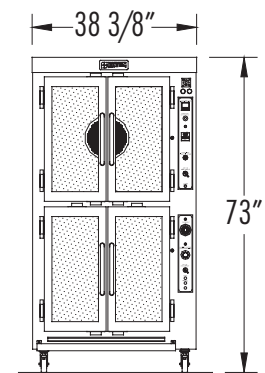

JAOP6SL  
Front

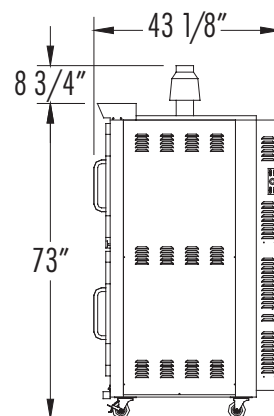

JAOP6SLG  
Side

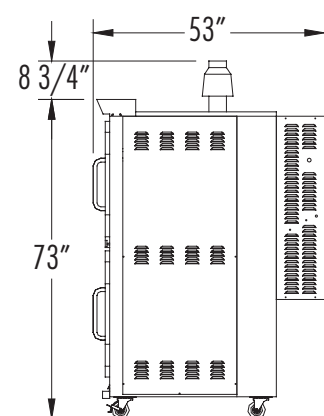

JAOP6G  
Side

Electrical service connection and water inlet are located at the back of the unit.

Specifications and design are subject to change without notice.



5600 13th Street • Menominee, MI 49858 USA

Phone: 906-863-4401

E-mail: sales@nu-vu.com

Toll Free: 1-800-338-9886

www.doyon.qc.ca

Fax: 906-863-5889

www.nu-vu.com