

DL18SP, DL18DP & DL18P

*“Superior quality product
at an affordable price !”*



DL18SP



DL18P



DL18DP

DOUGH SHEETER

Standard Features

- Compact design, ideal for use in limited space
- Sanitary, heavy duty, all stainless steel welded construction
- Spring loaded scrapers easily removable for cleaning
- Simple handle adjustments for exact uniform dough thickness
- Ergonomic design for easy operation
- Large hopper accepts large pieces of dough
- Convenient all-in-front operation
- Maintenance free drive mechanism
- Drive mechanism is isolated from roller area
- Sanitary plastic precision ground rollers
- 1" (25 mm) sanitary legs with rubber boots
- Will sheet up to 17" (432 mm) diameter
- Sealed ball bearings, permanently lubricated
- Fully adjustable
- One operator can make up to 250 pieces per hour
- ETL & ETL Sanitation listed
- One year parts and labor limited warranty

OPTIONAL

- Foot switch control for DL18DP
- 220V - 1PH - 50 Hz
- Model conform to requirements of RSST, conforms to the following norms and requirements:
 - EN 954-1 article 6.2.1
 - CSA Z432-04, articles 6.2.1.9.2, 6.2.1.9.3, 6.2.1.9.4, 6.2.3.2, 7.17, 10.2
 - RSST articles 172 à 175, 182, 184, 187, 189, 190, 192

DL18 series Counter top dough sheeter

The Doyon DL18 series dough sheeter is an efficient one (DL18SP) or two stage (DL18DP & DL18P) machine featuring a front infeed and discharge. Ergonomic design makes it easy and simple to operate.

Pizza and pie shells are made easily with this compact, counter top design that is simple to use. Simply drop a floured dough ball at the top and pick the sheeted dough piece at the bottom.

Sheet dough up to 17" (432 mm) in diameter to a uniform thickness in seconds. One operator can make up 250 pieces per hour .

Simple, fast and economical. Sheet pie crusts or pizza shells up to 17" (432 mm). The DL18 series features large diameter rollers and a Quick Change Index System to quickly change the gap between the dough rollers.

Ideal for: Pizza (up to 17"- 432 mm), Tortillas, Calzones, Focaccia Roti, Pita Bread, Flat Bread

DIMENSIONS

DL18DP

20 1/2"W X 11 1/2"D X 27 1/4" H
(520 mm X 290 mm X 690 mm)

Top Rollers: 2" X 10 1/2" (51 mm X 267 mm)

Bottom Rollers: 2" X 18" (51 mm X 457 mm)

DL18P

22"W X 11 1/2"D X 27 1/2" H
(560 mm X 290 mm X 700 mm)

Top Rollers: 2" X 10 1/2" (51 mm X 267 mm)

Bottom Rollers: 2" X 18" (51 mm X 457 mm)

DL18SP

22"W X 11 1/2"D X 13" H
(560 mm X 290 mm X 330 mm)

Rollers: 2" X 18" (51 mm X 457 mm)

ELECTRICAL SYSTEM

120V - 1 PH - 370 Watts - 60 Hz

Heavy duty, maintenance free 1/2 HP motor

CAPACITY

Sheets from 1oz to 28oz (30g to 800g) of dough

Maximum rollers gap : 13/64" (5 mm)

Up to 250 dough pieces per hour

Finish

Stainless steel

SHIPPING WEIGHT

100 lb (45 kg) approximately

Specifications and design subject to change without notice.

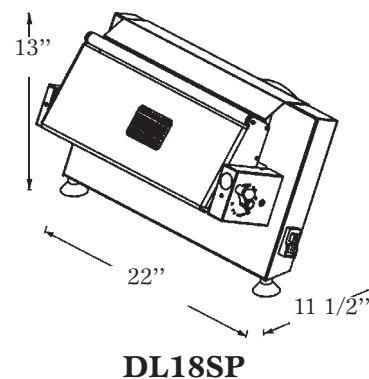
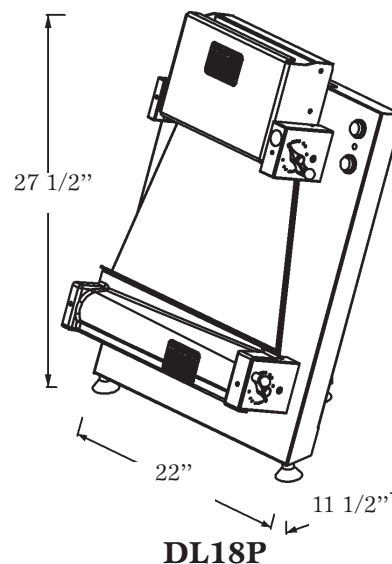
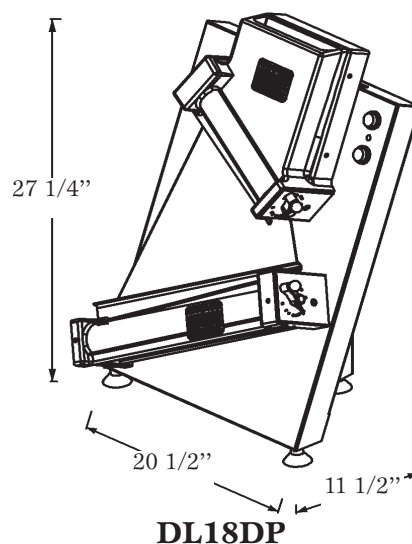

Foot switch control for
DL18DP



1255, rue Principale
Linière, Beauce, Québec, Canada G0M 1J0

Telephone : (418) 685-3431 Fax: (418) 685-3948
Canada : (800) 463-1636 U.S.: (800) 463-4273
E-Mail : doyon@doyon.qc.ca Internet: <http://www.doyon.qc.ca>



Conforms to ANSI/UL std. 763 Conforms to
Certified to CSA C22.2 no.195 ANSI/NSF8

Your local distributor:

