



www.doyon.qc.ca • www.nu-vu.com

JA6

JET-AIR OVEN

The JA series from Doyon is known worldwide for its unique JET AIR SYSTEM. The air moves in one direction, stops then moves the other way resulting in a bidirectional and gentle velocity air flow for exceptional baking results. This system will help you bake faster and more evenly without having to turn pans during baking time. The Jet Air fan system will save energy and labor costs.

The JA6 provides great flexibility in terms of range of products that can be baked or cooked. It features a programmable or manual one shot and constant pulse steam injection. To get the results you really want, we have added as standard a fan delay for those delicate products.



JA6SL

(shown with optional stand)



JA6

(shown with optional stand)

STANDARD FEATURES

OVEN

- Outstanding steam shot and pulse injection system
- Reversing fan system
- Two speeds fan
- Fan delay switch
- High production oven
- Manual mode and user friendly E Bake programmable control up to 99 recipes
- Digital temperature control up to 500°F
- Digital reminder timer
- USB Port
- Brightly lit, compact space saving unit
- Full view heat reflective thermal glass doors
- Fully insulated, completely sealed
- Energy efficient electric or gas heating (baking temperature reached in 15 minutes)
- Magnetic latches
- Door switch cutoff for fan blower
- Stainless steel inside and outside
- 3/4 HP motor
- 2 year parts 1 year labor limited warranty

OPTIONS

- Stand with locking casters for JA6SL (JA6SLB)
- Stand with locking casters for JA6 (JA6B)
- Water softener: PLF240
- Gas quick disconnect kit (4' (1120 mm) flexible hose, ball valve and securing device)

Experience our top-of-the-line ovens today!



5600 13th Street • Menominee, MI 49858 USA

Phone: 906-863-4401 E-mail: sales@nu-vu.com
Toll Free: 1-800-338-9886 www.doyon.qc.ca
Fax: 906-863-5889 www.nu-vu.com

OVERALL DIMENSIONS

JA6 36 1/2" W X 48 1/4" D X 34 3/4" H

(927 mm X 1225 mm X 883 mm)

JA6G 36 1/2" W X 52 3/4" D X 34 3/4" H

(927 mm X 1321 mm X 883 mm)

JA6SL 38 3/8" W X 37 5/8" D X 34 5/8" H

(975 mm X 956 mm X 879 mm)

ELECTRICAL SYSTEM

JA6 - JA6SL

1 Phase:

208V- 51 A - 10.8 kW - 60 Hz - 2 wires + Ground

240V- 45 A - 10.8 kW - 60 Hz - 2 wires + Ground

3 Phases:

208V- 33 A - 10.8 kW - 60 Hz - 3 wires + Ground

240V- 28 A - 10.8 kW - 60 Hz - 3 wires + Ground

Other voltages available

GAS SYSTEM

JA6G (Propane or natural)

BTU total: 65 000

Voltage:

1 Phase:

120V - 6.5A - 0.8 kW - 60Hz - 2 wires + Ground NEMA 5-15P

Gas inlet: 1/2" NPT

Draft hood : 4" (102 mm)

Recommended gas pressure:

Propane gas : 11" W.C.

Natural gas : 7" W.C.

WATER INLET: 1/4" NPT

Minimum clearance from combustibile material

1" (25 mm) side and back

4" (102 mm) on non combustibile floor

12" (305 mm) top

FINISH: Stainless steel

SHIPPING WEIGHT

JA6: 700 lb (318 kg) approximately

JA6G: 760 lb (345 kg) approximately

JA6B: 170 lb (77 kg) approximately

JA6SL: 700 lb (318 kg) approximately

JA6SLB: 170 lb (77 kg) approximately

Electrical service connection and water inlet are located at the back of the unit.

Specifications and design are subject to change without notice.

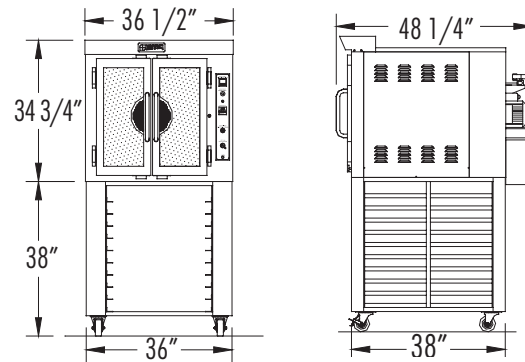

JA6
Front

JA6
Side

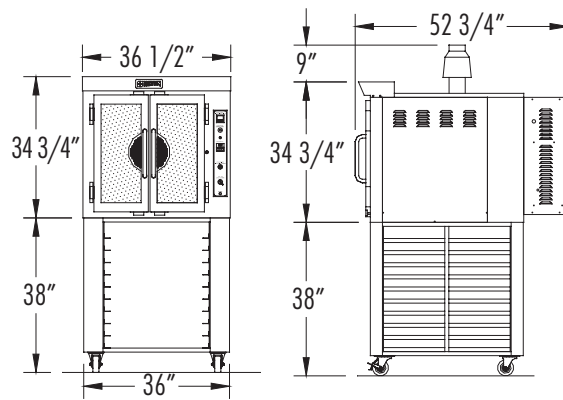

JA6G
Front

JA6G
Side

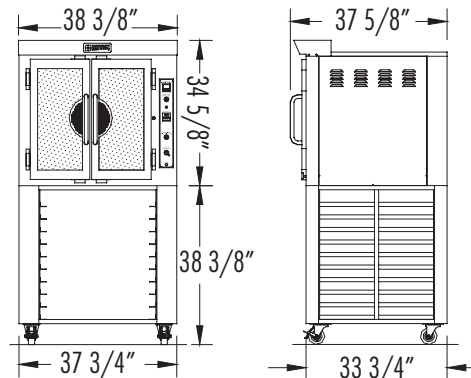

JA6SL
Front

JA6SL
Side



5600 13th Street • Menominee, MI 49858 USA

Phone: 906-863-4401

E-mail: sales@nu-vu.com

Toll Free: 1-800-338-9886

www.doyon.qc.ca

Fax: 906-863-5889

www.nu-vu.com