

pizzaXpress



Model No.

DXP-PB-2-8

8" Par-Bake & Form Press

Personal Size Pizza Press is exciting way to par bake and form the perfect 8" personal size pizza crusts using your own pizza dough. Prepare pizza crust ahead of the rush. Crusts hold for hours refrigerated and longer frozen. Xylan coated platens make dough removal and clean-up an easy task. Compact size fits anywhere. Electronic timer with buzzer, 0-60 seconds.

- Prepare pizza crust ahead of the lunch rush.
- Crusts hold for hours refrigerated and longer frozen.
- PTFE coated platens make dough removal and clean-up an easy task.
- Compact size fits anywhere.
- Electronic timer with buzzer, 0-60 seconds.

The DXP-PB-2-8 is a counter top model and is operated manually. This press features both forming and baking in a single operation. It offers an 8" Diameter Mold.

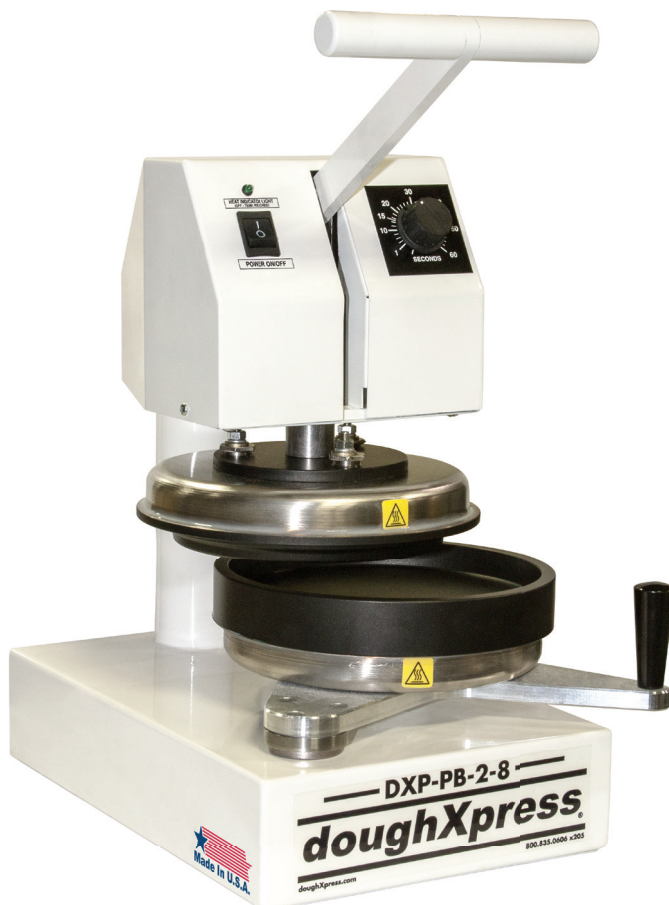

Heated upper & Lower Platens:

- Aids dough flow
- Allows dough to be pressed straight from the refrigerator unit
- Keeps dough from sticking to the upper & lower platens
- Temperature is pre-set to 430°F on both the lower & upper platens

Use:

- DXP-PB-2-8 is easy to use...prepare approximately 5 ounce round dough balls (Weights can vary depending on thickness desired)
- Place dough ball on the center of lower platen and pull handle down until the buzzer sounds off and release handle than remove crust

Production:

- Pending par-bake desired your results should produce a par-bake crust every 45-60 seconds. Time will vary pending on the par-bake of the crust desired

Labor:

- The press requires no skilled labor
- Presses are safe and have no age requirement

Finished Product:

- The crust should result into crispy light brown crust ready for toppings and final bake for serving



doughXpress

HIX Corporation Food Division

Product improvement may require us to change specifications without notice.

Revised March 2014

DOUGHXPRESS

1201 E. 27th Terrace
Pittsburg, KS 66762 USA

Toll Free: (800) 835-0606 ext.205

Tel: (620) 231-8568 ext.205

Fax: (620) 231-1598

doughxpress@hixcorp.com or visit www.doughxpress.com

pizzaXpress



Model No.

DXP-PB-2-8

8" Par-Bake & Form Press

Features Include:

- Preset temperature to 430°F
- Electronic timer – variable 0-60 seconds
- On-Off Switch
- Pilot light – Light will shut-off when temperature is reached
- Presses to 8 inch crust with a rim
- White powder coated unit
- Non-stick PTFE coated upper and lower platens

Recommended Cleaning Instructions:

- Wipe down with moist towel – if needed, use damp sponge with minimal soap and water and then dry off

DIMENSIONS

Width: 11-9/16 in., 29.37 centimeters
 Height: 20-21/32 in., 52.47 centimeters
 Depth: 14-1/2 in., 36.83 centimeters

WEIGHT

Press Only: 58 lbs. Shipping Wt: 65 lbs

ELECTRICAL

208~240 Volt 50/60 Hz
 2800 Watts
 11.7 Amps
 6-15P NEMA Plug

TEMPERATURE RANGE

Fixed 430°F (221°C) upper/lower platens

Easy As...

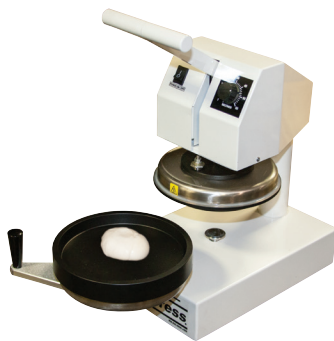

1.



2.



3.

Place pre-portioned ball of dough in lower platen.

Set desired time. After heat indicating light has gone out, pull down the handle. When timer sounds, pull up the handle.

Remove your crust from the platen. Crust is ready for saucing and adding toppings.

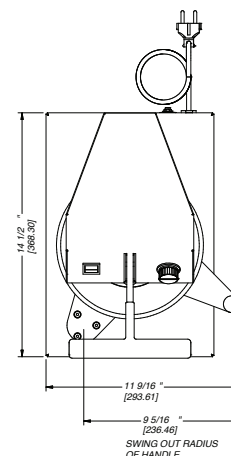
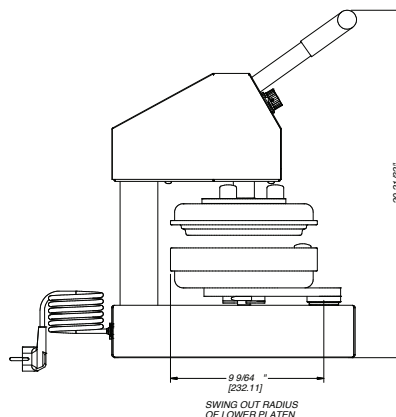
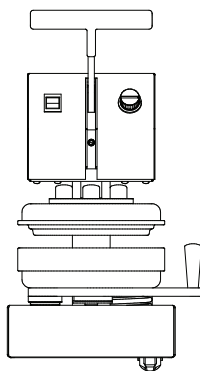

doughXpress

HIX Corporation Food Division
 Product improvement may require us to change specifications without notice.
 Revised March 2014

DOUGHXPRESS
 1201 E. 27th Terrace
 Pittsburg, KS 66762 USA

Toll Free: (800) 835-0606 ext.205
 Tel: (620) 231-8568 ext.205
 Fax: (620) 231-1598

doughxpress@hixcorp.com or visit www.doughxpress.com