



Profit from the Eagle Advantage®

# Specification Sheet

## Short Form Specifications

Eagle Director's Choice® Tray Platform Unit, model DCS2-TPU. Top to be 16/304 stainless steel turned down on all sides. 1½" square type 304 stainless steel all-welded tubular base. Removable solid bottom panel will store up to 200 trays, and furnished with ten nylon silverware cylinders. Fully mobile with 5" poly casters, two with brake.



#DCS2-TPU tray platform unit

Item No.:	_____
Project No.:	_____
S.I.S. No.:	_____

## Director's Choice® Tray Platform Unit

MODEL:  
 DCS2-TPU

### Design and Construction Features

- Welded 1½" (38mm) type 304 stainless steel square tubular base construction.
- Open frame features 1½" (38mm) square stainless steel tubing.
- Fully mobile - standard 5" (127mm) swivel casters, two with brake.
- Removable two-section undershelf.
- Includes ten white dishwasher-safe nylon silverware cylinders.
- Holds up to 200 trays.
- 24" (610mm) front-to-back, 36" (914mm) side-to-side.
- 39" (991mm) overall height.

### Options / Accessories \*

\* This is a freestanding unit not designed to lock together with other units. Optional laminates, front/end panels, tray slides, workboards, and serving shelves do not apply.

**EAGLE GROUP**  
100 Industrial Boulevard, Clayton, DE 19938-8903 USA  
Phone: 302-653-3000 • Fax: 302-653-2065  
www.eaglegrp.com

**Foodservice Division: Phone 800-441-8440**  
**MHC/Retail Display Divisions: Phone 800-637-5100**

For custom configuration or fabrication needs, contact our **SpecFAB® Division**.  
Phone: 302-653-3000 • Fax: 302-653-3091 • e-mail: specfab@eaglegrp.com



EG33.21 Rev. 08/08

**Spec sheets available for viewing, printing or downloading from our online literature library at [www.eaglegrp.com](http://www.eaglegrp.com)**



Item No.: \_\_\_\_\_  
 Project No.: \_\_\_\_\_  
 S.I.S. No.: \_\_\_\_\_

## Director's Choice® Tray Platform Unit

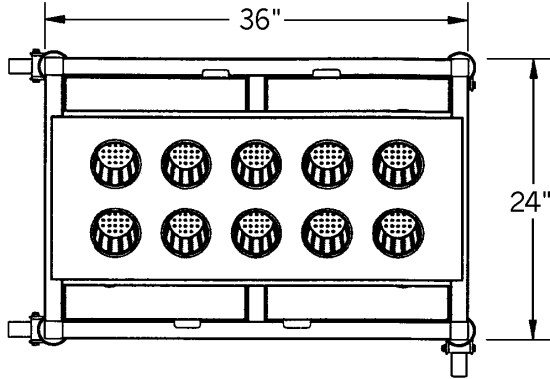

TOP VIEW

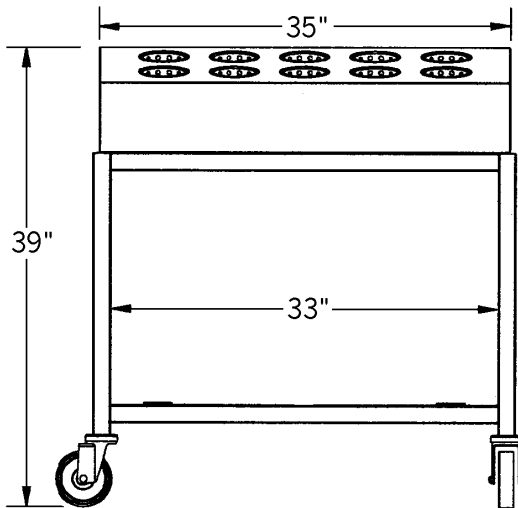

FRONT VIEW

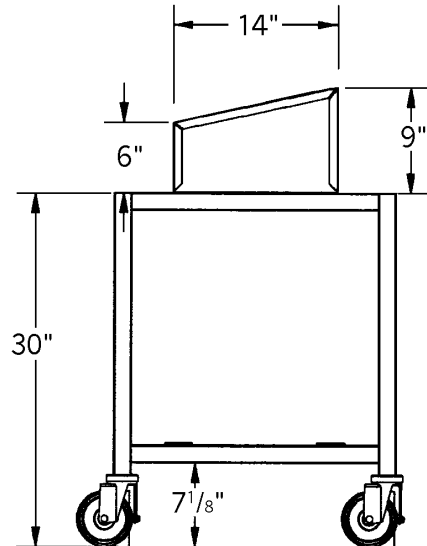

SIDE VIEW

model #	width		length		weight	
	in.	mm	in.	mm	lbs.	kg
DCS2-TPU	24"	610	36"	914	250	113.4

**EAGLE GROUP**  
 100 Industrial Boulevard, Clayton, DE 19938-8903 USA  
 Phone: 302-653-3000 • Fax: 302-653-2065  
 www.eaglegrp.com

Foodservice Division: Phone 800-441-8440  
 MHC/Retail Display Divisions: Phone 800-637-5100

Printed in U.S.A.  
 ©2008 by Eagle Group  
 Rev. 08/08

Spec sheets available for viewing, printing or downloading from our online literature library at [www.eaglegrp.com](http://www.eaglegrp.com)

Although every attempt has been made to ensure the accuracy of the information provided, we cannot be held responsible for typographical or printing errors. Information and specifications are subject to change without notice. Please confirm at time of order.