



Profit from the Eagle Advantage®

Specification Sheet

Short Form Specifications

Eagle Biscuit Workstation, model TSB2460Z, to consist of two 1460C chrome-plated overshelves, two 1860C chrome-plated undershelves, 24" x 60" stainless steel tabletop, 33" front posts, and 63" rear posts. Two light-duty utility shelves, two wire baskets, and two spice racks mount onto rear grid panel. Five shelf dividers included.



(spice racks and utility shelves not shown, microwave not included)

Options / Accessories

- Shelving ledges
- Additional dividers
- Shelf markers

EAGLE GROUP

100 Industrial Boulevard, Clayton, DE 19938-8903 USA

Phone: 302-653-3000 • Fax: 302-653-2065

www.eaglegrp.com

Foodservice Division: Phone 800-441-8440

MHC/Retail Display Divisions: Phone 800-637-5100

For custom configuration or fabrication needs, contact our **SpecFAB®** Division.

Phone: 302-653-3000 • Fax: 302-653-3091 • e-mail: specfab@eaglegrp.com

Item No.:	_____
Project No.:	_____
S.I.S. No.:	_____

Biscuit Workstation

MODELS:

- TSB2460Z

- Keeps task-related items together.
- Two 14" x 60" (356 x 1524mm) chrome wire overshelves.
- Two 18" x 60" (457 x 1524mm) chrome wire undershelves.
- 24" x 60" (610 x 1524mm) 16 gauge type 304 stainless steel tabletop with hat channel supports.
- 33" (762mm) chrome front posts.
- 29" (737mm) chrome front posts for overshelves.
- 63" (1600mm) chrome rear posts.
- All posts are numbered and grooved at 1" (25mm) increments for fast and level assembly.
- Two wire baskets: 13 3/4" L x 5" W x 7" D (340 x 127 x 178mm).
- Two light-duty utility shelves: 11 1/4" L x 8" W x 3 1/2" D (286 x 203 x 89mm).
- Two zinc-plated spice racks: 14" L x 2" W (356 x 51mm).
- Five 8" x 14" (203 x 356mm) chrome shelf dividers, for use typically with lower overshelf.
- 24" x 60" (610 x 1524mm) rear wire grid panel accommodates baskets, utility shelves, spice racks and various hanging accessories.
- 34" (864mm) working height.





Item No.: _____
 Project No.: _____
 S.I.S. No.: _____

Biscuit Workstation

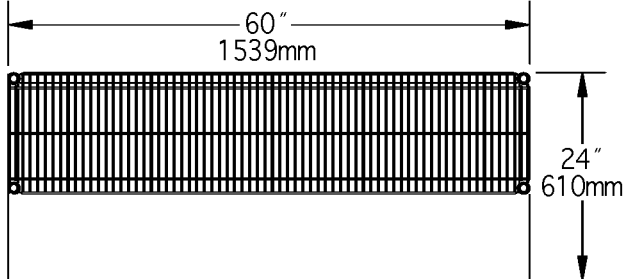

TOP VIEW

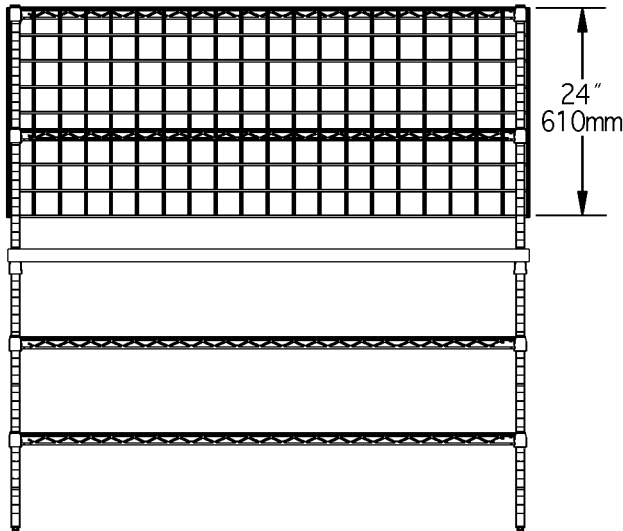

FRONT VIEW

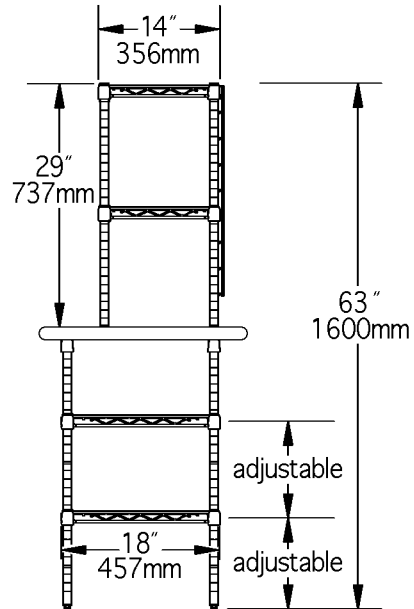

SIDE VIEW

(shown without baskets etc. mounted to rear grid panels)

model #	width		length		height		weight	
	in.	mm	in.	mm	in.	mm	lbs.	kg
TSB2460Z	24"	610	60"	1524	63"	1600	189	85.7

EAGLE GROUP
 100 Industrial Boulevard, Clayton, DE 19938-8903 USA
 Phone: 302-653-3000 • Fax: 302-653-2065
 www.eaglegrp.com

Foodservice Division: Phone 800-441-8440
 MHC/Retail Display Divisions: Phone 800-637-5100

Printed in U.S.A.
 ©2010 by Eagle Group
 Rev. 11/10

Spec sheets available for viewing, printing or downloading from our online literature library at www.eaglegrp.com

Although every attempt has been made to ensure the accuracy of the information provided, we cannot be held responsible for typographical or printing errors. Information and specifications are subject to change without notice. Please confirm at time of order.