



Profit from the Eagle Advantage®

Specification Sheet

Short Form Specifications

Eagle Drive-Through Task Station, model TSD3660Z, to consist of heavy gauge 36" x 60" galvanized steel tabletop, 36" x 60" wire undershelf, one 12" x 60" cantilever undershelf, two 1460Z EAGLEbrite® zinc-plated wire overshelves with 74" EAGLEbrite® zinc-plated posts, and two bin holders to accommodate 14 standard 5"-deep plastic supply bins.

Item No.:	_____
Project No.:	_____
S.I.S. No.:	_____

Drive-Through Task Station

MODELS:

TSD3660Z



(equipment shown not included)

- Keeps work-related items together.
- Two 14" x 60" (356 x 1524mm) zinc-plated wire shelves for overhead storage. Shelf heights can be adjusted.
- 14 plastic supply bins: 10 1/2" L x 5 1/2" W x 5" D (276 x 140 x 127mm).
- Two chrome-plated full-length bin holders. Heights can be adjusted.
- One 12" (305mm)-wide full-length chrome-plated cantilever shelf mounted to front posts underneath tabletop.
- Posts are numbered and grooved at 1" (25mm) increments for fast and level assembly.
- 18 gauge galvanized steel tabletop with aluminum corner castings.
- 36" x 60" (914 x 1524mm) zinc-plated wire undershelf.
- One 13 3/4" x 5" x 7" (340 x 127 x 178mm) chrome-plated wire basket with two 6-gauge wire S-hooks.
- 34" (864mm) working height.
- 74" (1880mm) overall post height.

EAGLE GROUP

100 Industrial Boulevard, Clayton, DE 19938-8903 USA

Phone: 302-653-3000 • Fax: 302-653-2065

www.eaglegrp.com

Foodservice Division: Phone 800-441-8440

MHC/Retail Display Divisions: Phone 800-637-5100

For custom configuration or fabrication needs, contact our SpecFAB® Division.

Phone: 302-653-3000 • Fax: 302-653-3091 • e-mail: specfab@eaglegrp.com



EG01.52 Rev. 11/10

Spec sheets available for viewing, printing or downloading from our online literature library at www.eaglegrp.com

Eagle Foodservice Equipment, Eagle MHC, SpecFAB®, and Retail Display are divisions of Eagle Group. ©2010 by the Eagle Group



Profit from the Eagle Advantage®

Item No.: _____
 Project No.: _____
 S.I.S. No.: _____

Drive-Through Task Station

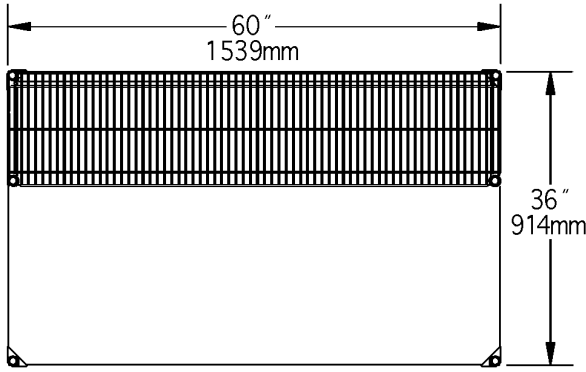

TOP VIEW

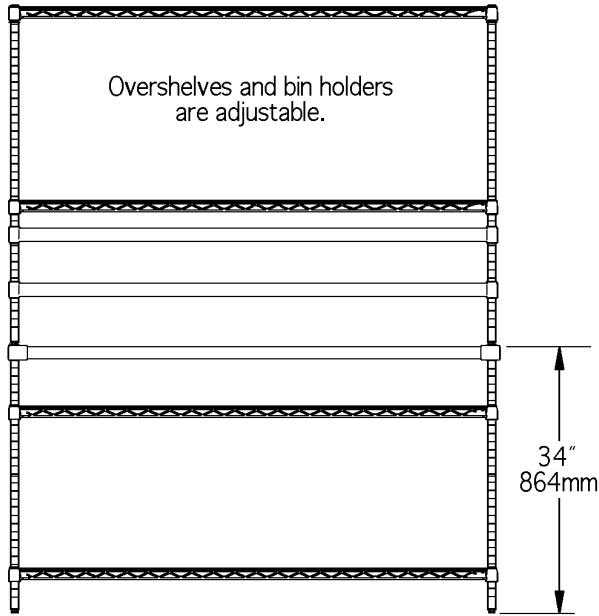

FRONT VIEW

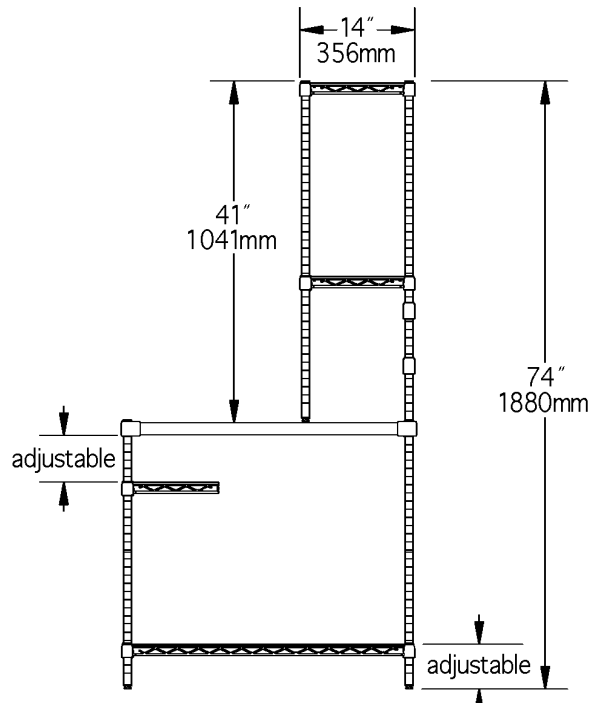

SIDE VIEW

(Note: shown without supply bins)

model #	width		length		height		weight	
	in.	mm	in.	mm	in.	mm	lbs.	kg
TSD3660Z	36"	914	60"	1524	74"	1880	168	76.2

EAGLE GROUP
 100 Industrial Boulevard, Clayton, DE 19938-8903 USA
 Phone: 302-653-3000 • Fax: 302-653-2065
 www.eaglegrp.com

Foodservice Division: Phone 800-441-8440
 MHC/Retail Display Divisions: Phone 800-637-5100

Printed in U.S.A.
 ©2010 by Eagle Group
 Rev. 11/10

Spec sheets available for viewing, printing or downloading from our online literature library at www.eaglegrp.com

Although every attempt has been made to ensure the accuracy of the information provided, we cannot be held responsible for typographical or printing errors. Information and specifications are subject to change without notice. Please confirm at time of order.