



Profit from the Eagle Advantage®

Specification Sheet

Short Form Specifications

Eagle Full Size Hot Food Merchandising Cart, model HDC48-120NYF. Heavy gauge stainless steel construction with two insulated heating wells, color-coordinated umbrella, one full-size 12" x 20" pan with hinged lid, one 3/8-size inset with hinged lid, and one 1/2-size inset with hinged lid and two 1/4-qt. insets inside. Two 20" ball bearing wheels with rubber tires and one 8" swivel caster. 120-volt 20-amp cord and plug.



Item No.:	_____
Project No.:	_____
S.I.S. No.:	_____

Hot Food Merchandising Cart

MODEL:

HDC48-120NYF

Design and Construction Features

- Stainless steel construction.
- Two insulated heating wells.
- Solid top work surface.
- Complete with cord and 120-volt 20-amp NEMA 5-20 plug.
- 20" (508mm) ball bearing wheels with rubber tires.
- One 8" (203mm) diameter swivel caster.
- One full-size inset with roll top cover.
- One 3/8-size inset with hinged lid.
- One 1/2-size inset with hinged lid with two 1/4-quart insets inside.
- Color-coordinated umbrella.

Options / Accessories

- Tongs
- Ladles

EAGLE GROUP
 100 Industrial Boulevard, Clayton, DE 19938-8903 USA
 Phone: 302-653-3000 • Fax: 302-653-2065
 www.eaglegrp.com

Foodservice Division: Phone 800-441-8440
MHC/Retail Display Divisions: Phone 800-637-5100

For custom configuration or fabrication needs, contact our **SpecFAB® Division**.
 Phone: 302-653-3000 • Fax: 302-653-2065 • e-mail: quotes@eaglegrp.com



AUTOQUOTES



EG35.05 Rev. 03/15

Spec sheets available for viewing, printing or downloading from our online literature library at www.eaglegrp.com

Eagle Foodservice Equipment, Eagle MHC, SpecFAB®, and Retail Display are divisions of Eagle Group. ©2015 by the Eagle Group



Item No.: _____
 Project No.: _____
 S.I.S. No.: _____

Hot Food Merchandising Cart

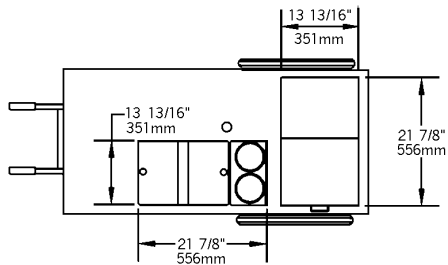

TOP VIEW

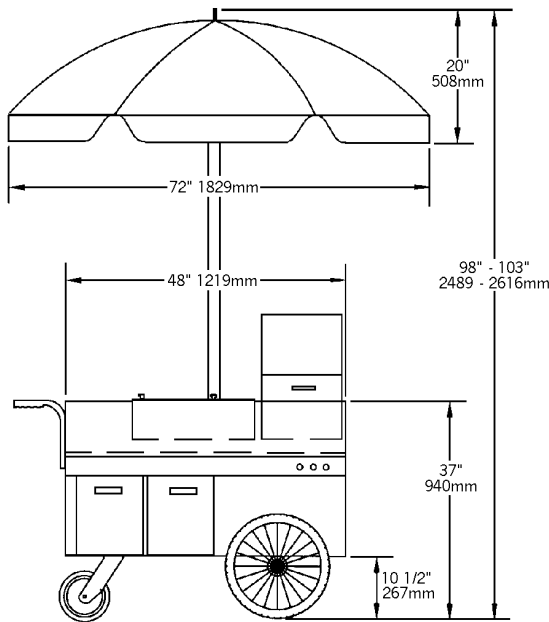

SIDE VIEW

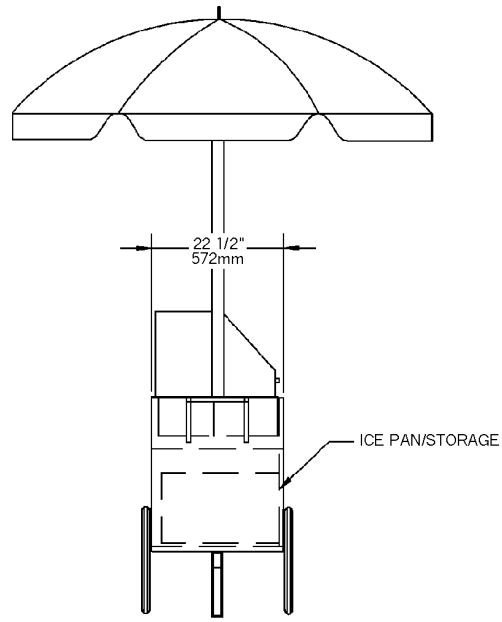

FRONT VIEW

model #	width		length		weight		description
	in.	mm	in.	mm	lbs.	kg	
HDC48-120NYF	22 1/2"	572	48"	1219	467	212	with hinged lids

EAGLE GROUP
 100 Industrial Boulevard, Clayton, DE 19938-8903 USA
 Phone: 302-653-3000 • Fax: 302-653-2065
 www.eaglegrp.com

Foodservice Division: Phone 800-441-8440
 MHC/Retail Display Divisions: Phone 800-637-5100

Printed in U.S.A.
 ©2015 by Eagle Group
 Rev. 03/15

Spec sheets available for viewing, printing or downloading from our online literature library at www.eaglegrp.com

Although every attempt has been made to ensure the accuracy of the information provided, we cannot be held responsible for typographical or printing errors. Information and specifications are subject to change without notice. Please confirm at time of order.