

General Information

Project Name: _____

Consultant: _____

Item #: _____

Model #: _____

Quantity: _____



Specifications

ESTP Equipment Stand w/ Scrap Tray is constructed of 16GA S/S top and 18GA S/S undershelf type 300 series. Legs are constructed of 1^{5/8}" tubing, 16GA S/S with adjustable bullet feet.

Understructure has 16GA S/S channeling welded to top to support heavy equipment.

Perforated area in top is 11^{1/4}" x 19^{1/2}" w/ 1/2" diameter holes which allows crumbs to fall into a scrap tray. Scrap tray is 12" x 20" x 2" deep and easily slides in and out for scrap clean up.

Unit is 30" x 30" x 34" high w/ 2" splashes on three sides. S/S hook on side is for hanging counter brush when not in use.

Product Guide

Stainless steel equipment stand is engineered for heavy use and years of service in high volume Institutional, Commercial, or large food prep facilities.

Perforated area and scrap tray makes cleanup easy.

Options

- RC-5** - 5" Dia. Rubber Casters
- PCY-5** - 5" Poly Casters - Heavy Duty
- GA-14** - 14GA Upgrade
- Custom Sizes
- CR** - Crossrails
- Replacement Scrap Tray
- FF-50** - S/S Flanged Feet



ESTP-20 0619

DRAWINGS

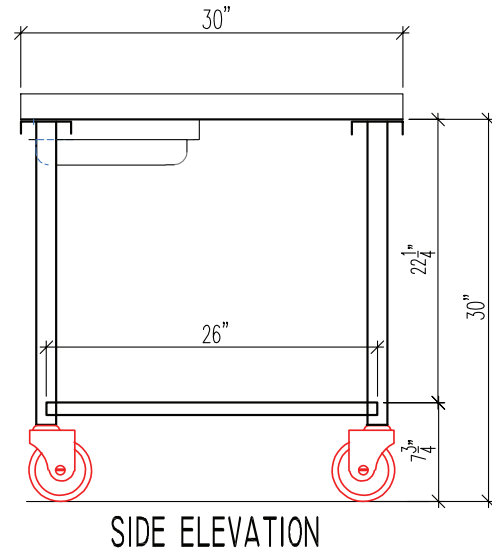
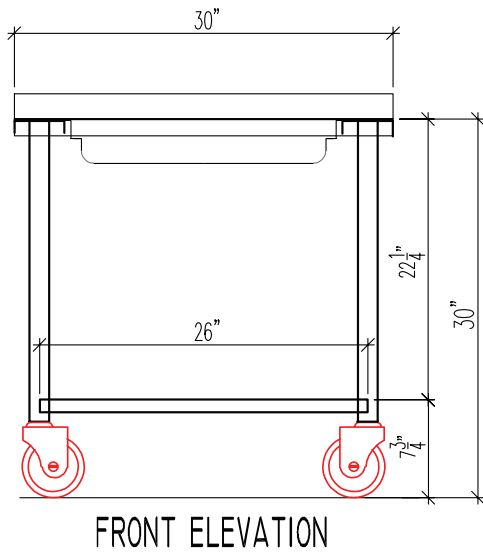
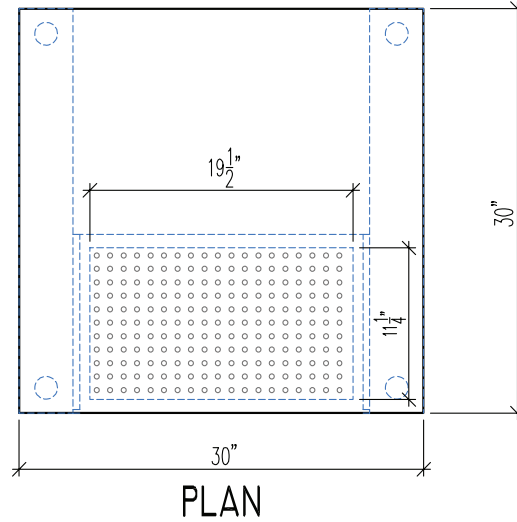

EQUIPMENT STAND W/ SCRAP TRAY

Model	Size (W x L)
□ ESTP-24	30" x 24"
□ ESTP-30	30" x 30"
□ ESTP-36	30" x 36"
□ ESTP-48	30" x 48"
□ ESTP-60	30" x 60"
□ ESTP-72	30" x 72"
□ ESTP-84	30" x 84"
□ ESTP-96	30" x 96"

Specifications subject to change without notice.

ESTP-20 0619