



EVERPURE® INSURICE® QUAD - i4000² SYSTEM

DELIVERS PREMIUM QUALITY WATER FOR ICE APPLICATIONS

Insurice Quad-i4000² System: EV9325-04
i4000² Replacement Cartridge: EV9612-32



APPLICATIONS

Ice Machine
Higher Volume, Higher Flow and Higher Capacity Ice Machines

FEATURES • BENEFITS

Reduces ice machine problems caused by scale buildup from dirt and dissolved minerals

Sanitary cartridge replacement is simple, quick and clean

Reduces maintenance and service costs by reducing scale* and clogging of distribution lines, evaporator plate and pump

Exclusive precoat filtration provides superior chlorine taste & odor reduction and micro-filters dirt and particles as small as 0.5 micron in size by mechanical means

Proprietary Micro-Pure® II filtration media effectively inhibits the growth of bacteria on the filter media that can decrease product life

Reduces chlorine taste & odor and other offensive contaminants

Self-contained scale inhibitor feed keeps ice machines functioning at full capacity*

Manifold features water shut-off, flushing valve and outlet pressure gauge

NSF/ANSI Standard 53 certified to reduce cysts such as *Cryptosporidium* and *Giardia* by mechanical means

*As tested by Pentair

INSTALLATION TIPS

Choose a mounting location suitable to support the full weight of the system when operating.

Never use saddle valve for connection.

Use 3/4" water line.

Do not connect system to water-cooled condenser.

Install vertically with cartridges hanging down and allow 2-1/2" (6.35 cm) clearance below the cartridge for easy cartridge replacement.

Flush cartridges by running water through system for five (5) minutes at full flow.

OPERATION TIPS

Change cartridges on a regular six (6) month preventative maintenance program.

Change cartridges when capacity is reached or when pressure falls below 10 psi (0.7 bar).

Service flow rate must not exceed 6.7 gpm (25.3 Lpm).

Always flush the filter cartridge at time of installation and cartridge change.

SIZING

Service Flow Rate: Maximum 6.68 gpm (25.3 Lpm)

EVERPURE® INSURICE® QUAD - i4000² SYSTEM

EV9325-04

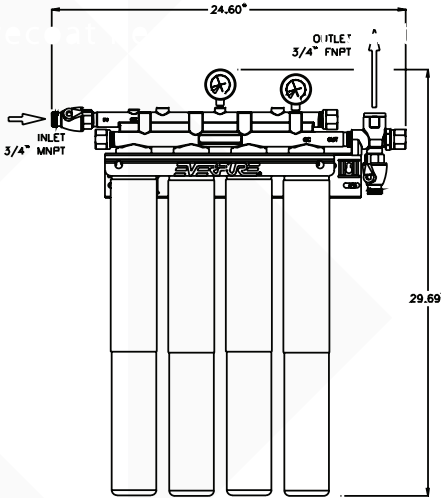

SPECIFICATIONS

Service Flow Rate

Maximum 6.68 gpm (25.3 Lpm)

Pressure Requirements

10 – 125 psi (0.7 – 8.6 bar), non-shock

Temperature

35 – 100°F (2 – 38°C)

Overall Dimensions

29.69" H x 24.6" W x 5.5" D
(75.4 cm x 62.4 cm x 13.9 cm)

Inlet Connection

3/4"

Outlet Connection

3/4"

Electrical Connection

None required

Shipping Weight

22 lbs (9.9 kgs)

Operating Weight

36 lbs (116.3 kgs)



System Tested and Certified by NSF International against NSF/ANSI Standards 42 and 53 for the reduction of:

STANDARD NO. 42 — AESTHETIC EFFECTS

- Chemical Reduction
- Taste & Odor
- Chlorine

- Mechanical Filtration
- Nominal Particulate, Class I

STANDARD NO. 53— HEALTH EFFECTS

- Mechanical Filtration
- Cyst Reduction

EPA No. 002623-IL-002

The contaminants or other substances removed or reduced by this drinking water system are not necessarily in your water. Do not use with water that is microbiologically unsafe or of unknown quality without adequate disinfection before or after the system. Systems certified for cyst reduction may be used with disinfected water that may contain filterable cysts.

WARRANTY

Everpure water treatment systems by Pentair® (excluding replaceable elements) are covered by a limited warranty against defects in material and workmanship for a period of five years after date of purchase. Everpure replaceable elements (filter cartridges and water treatment cartridges) are covered by a limited warranty against defects in material and workmanship for a period of one year after date of purchase. See printed warranty for details. Pentair will provide a copy of the warranty upon request.



WATER QUALITY SYSTEMS

EVERPURE-SHURFLO WORLD HEADQUARTERS, 1040 MUIRFIELD DRIVE, HANOVER PARK, IL 60133 USA • FOODSERVICE.PENTAIR.COM
800.942.1153 MAIN (US ONLY) • 630.307.3000 MAIN • 630.307.3030 FAX • CSEVERPURE@PENTAIR.COM EMAIL

EVERPURE-SHURFLO AUSTRALIA, 1-21 MONASH DRIVE, DANDENONG SOUTH, VIC 3175, AUSTRALIA
011.1300.576.190 TEL • 011.61.39.562.7237 FAX • AU.EVERPURE@PENTAIR.COM EMAIL

EVERPURE-SHURFLO CHINA, 21F CLOUD 9 PLAZA, NO 1118, SHANGHAI, 200052, CHINA
86.21.3211.4588 TEL • 86.21.3211.4580 FAX • CHINA.WATER@PENTAIR.COM EMAIL

EVERPURE-SHURFLO INDIA, GREEN BOULEVARD, B-9/A, 7TH FLOOR - TOWER B SECTOR 62, NOIDA - 201301
91.120.419.9444 TEL • 91.120.419.9400 FAX • INDIACUSTOMER@PENTAIR.COM EMAIL

EVERPURE-SHURFLO EUROPE, PENTAIR WATER BELGIUM BVBA, INDUSTRIEPARK WOLFSTEE, TOEKOMSTLAAN, 30 B-2200 HERENTALS, BELGIUM
+32.(0).14.283.500 TEL • +32.(0).14.283.505 FAX • SALES@EVERPURE-EUROPE.COM EMAIL

EVERPURE-SHURFLO JAPAN INC., HASHIMOTO MN BLDG. 7F, 3-25-1 HASHIMOTO, MIDORI-KU, SAGAMIHARA-SHI KANAGAWA 252-0143, JAPAN
81.(0)42.775.3011 TEL • 81.(0)42.775.3015 FAX • INFO@EVERPURE.CO.JP EMAIL

EVERPURE-SHURFLO SOUTHEAST ASIA, SOUTHEAST ASIA, 390 HAVELOCK ROAD, #04-01, KING'S CENTRE, SINGAPORE 169662
65.6768.5800 TEL • 65.6737.5149 FAX • CSEVERPURE@PENTAIR.COM EMAIL

All Pentair trademarks and logos are owned by Pentair, Inc. or its affiliates. All other registered and unregistered trademarks and logos are the property of their respective owners. Because we are continuously improving our products and services, Pentair reserves the right to change specifications without prior notice. Pentair is an equal opportunity employer.