



EV9798-45

SR-X Feeder

Superior scale prevention and corrosion control



SRX Feeder: EV9798-45

SS-IMF Cartridge: EV9799-32

BENEFITS

A complete system that effectively targets scale in both hot and cold environments

Provides protection against equipment corrosion

A sophisticated blend of polyphosphate compound represents an advancement in scale inhibition

Patented design (patent no. 5,580,448) dispenses a controlled amount of Hydroblend™ for long-term protection and provides greater effectiveness than standard phosphate treatments

SS-10 cartridge is more effective in higher alkalinity/hardness/TDS/temperature installations.

Clear bowl and cartridge make it easy to determine when Hydroblend compound is exhausted

System includes SR-X housing, SS-IMF cartridge and Spacer

The SS-IMF is NSF Certified under NSF/ANSI Standard 42 for material requirements only

INSTALLATION TIPS

Choose a mounting location suitable to support the full weight of the system when operating

Make sure to properly lubricate O-ring prior to use

Use 3/4" water line (Optional reducer bushings included)

Install vertically with bowl hanging down

Allow 2-1/2" clearance below the cartridge for easy cartridge replacement

OPERATION TIPS

Deliming of equipment prior to application is recommended, but not required

Inspect SS-IMF cartridge at least every 6 months

Replace SS-IMF cartridge before Hydroblend™ compound is completely dissolved

Pre-existing equipment scale may come loose and clog equipment. Remove any loose scale to assure satisfactory operation

APPLICATION/SIZING

For scale reduction applications

Provides scale reduction for ice applications

SR-X Feeder

SPECIFICATIONS

Overall Dimensions:
12.44"H x 5.16"W x 5.5"D

Inlet connection: 3/4"

Outlet connection: 3/4"

Service Flow Rate:
Maximum 6.0 gpm (22.7 Lpm)

Pressure Requirements:
10 - 125 psi (0.7 - 8.6 bar), non-shock

Temperature: 35 - 100°F (2 - 38°C)

No electrical connection required

Shipping Weight: 4 lbs.

Operating Weight: 6 lbs.

**The ScaleStick® trademark is used pursuant to an agreement between PWC Enterprises and Everpure, Inc.

The contaminants or other substances removed or reduced by this drinking water system are not necessarily in your water. Do not use with water that is microbiologically unsafe or of unknown quality without adequate disinfection before or after the system. Systems certified for cyst reduction may be used with disinfected water that may contain filterable cysts.

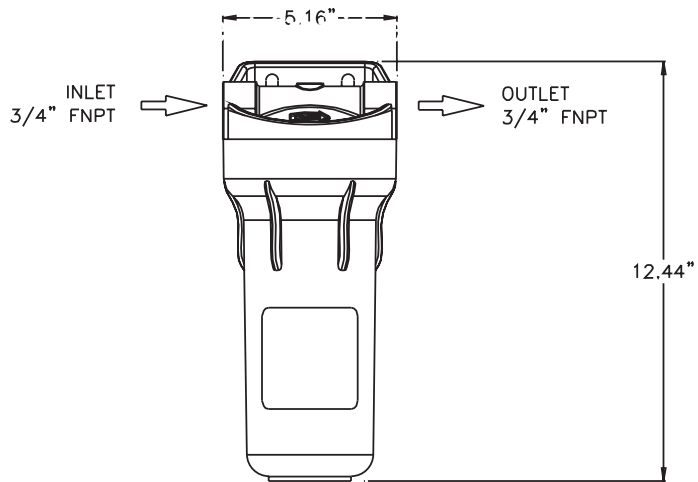

WARRANTY

Everpure water treatment systems (excluding replaceable elements) are covered by a limited warranty against defects in material and workmanship for a period of five years after date of purchase. Everpure replaceable elements (filter cartridges and water treatment cartridges) are covered by a limited warranty against defects in material and workmanship for a period of one year after date of purchase. See printed warranty for details. Everpure will provide a copy of the warranty upon request.

EVERPURE®

EVERPURE, INC.
2375 Sanders Road
Northbrook, IL 60062
Toll Free (800) 323-7873
Tel (847) 205-6000
Fax (800) 942-0081
<http://www.everpure.com>

In Europe:
N.V. EVERPURE (EUROPE) S.A.
Geldenaaksebaan 478
B-3001 Heverlee
Belgium
Tel 32-16-401191
FAX 32-16-402691

In Japan:
EVERPURE JAPAN, INC.
1-8-19, Tsumada Kita,
1-Chome, Atsugi City
Kanagawa Ken 243-0812
Japan
Tel 81-462-23-6563
FAX 81-462-21-6775

Everpure, Inc.
2375 Sanders Road
Northbrook, IL 60062
Phone: 800-323-7873 Fax: 800-942-0081