



EV4339-12

# Claris Large Filter Cartridge

Adjustable ion-selective filters to tailor carbonate hardness levels in potable water



Claris Large Cartridge: EV4339-12

## BENEFITS

### CARTRIDGE FEATURES

- 5-stage filtration process
- Pre-filtration
  - Carbonate hardness adjustment
  - Fine filtration
  - Highly efficient carbon block removes harmful contaminants and unpleasant odors and tastes
  - Solid membrane filter removes particles down to 5 micron for highest equipment protection
- Operation in vertical or horizontal position

## INSTALLATION TIPS

The system can be operated freestanding, lying horizontally or mounted vertically

If mounting vertically to a wall, securely connect the mounting bracket to the wall using suitable screws

Water pressure at the filter system inlet must not exceed 116 psi (8 bar). A pressure reducer valve must be installed on the water supply side of the filter system if the inlet pressure exceeds 116 psi (8 bar)

Shut off valve must be installed upstream of the filter

Refer to Installation, Operation & Maintenance Manual for cartridge flushing and start-up

## OPERATION TIPS

Change Claris cartridge when its pre-calculated water volume has been reached or at least once a year

Change cartridges when capacity is reached

Always flush the filter cartridge at time of installation and cartridge change

Do not use hardness test strips to check for hardness reduction, please use Titration kit to check for hardness reduction

## APPLICATION/SIZING

The CLARIS filter systems are typically used to feed the following appliances:

- Coffee and Espresso Machines
- Hot drink vending machines
- Combi steamers and self-cooking systems
- Steam cookers and ovens
- Brewed Iced Tea

The systems can be operated horizontally or vertically, depending on the space available

# Claris Water Filter Systems

## SPECIFICATIONS

### Overall Dimensions:

Large (A) 14.18" x (B) 5.35"

### Service Flow Rate:

Large 1.00 GPM (4 Lpm)

### Treatment Capacity:

See below and refer to Installation and Service guide for additional capacity guides.

### Pressure Requirements:

29 - 116 psi (2 - 8 bar), non-shock

Temperature: 39°F - 86°F (4 - 30°C)

No electrical connection required

Claris Large cartridge capacity is rated for 1100 gallons for Espresso applications and 1320 gallons for OCS/Coffee applications. This capacity is based on influent water hardness of 180 PPM with standard bypass settings. For steam applications and other hardness levels consult installation and operations guide capacity and bypass settings charts.

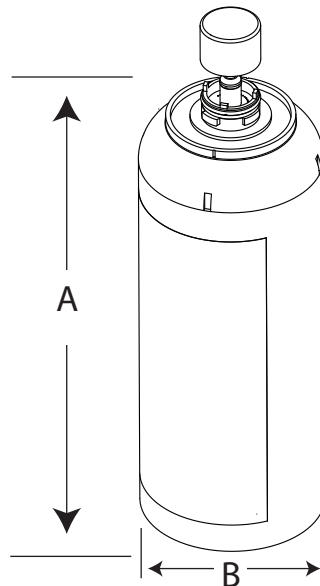

## WARRANTY

Everpure Claris water treatment systems are covered by a limited warranty against defects in material and workmanship for a period of one year after date of purchase. Everpure replaceable elements (filter cartridges and water are covered by a limited warranty against defects treatment cartridges) in material and workmanship for a period of one year after date of purchase. See printed warranty for details. Everpure will provide a copy of the warranty upon request.

The contaminants or other substances removed or reduced by this drinking water system are not necessarily in your water. Do not use with water that is microbiologically unsafe or of unknown quality without adequate disinfection before or after the system. Systems certified for cyst reduction may be used with disinfected water that may contain filterable cysts.



EVERPURE, LLC  
1040 Muirfield Drive  
Hanover Park, IL 60133  
Toll Free (800) 323-7873  
Tel. (630) 307-3000  
Fax (630) 307-3030  
www.everpure.com

In Europe:  
PENTAIR WATER BELGIUM bvba  
Industriepark Wolfstee  
Toekomstlaan 30  
B-2200 Herentals  
Belgium  
Tel. 32-14-283-500  
Fax 32-14-283-505

In Japan:  
EVERPURE JAPAN, INC.  
Hashimoto MN Bldg, 7F  
3-25-1 Hashimoto Sagamihara-Shi  
Kanagawa 229-1103  
Japan  
Tel. 81-(0)42-775-3011  
Fax 81-(0)42-775-3015