



EV9799-11

Kleenware HTS-11 System

Scale prevention and corrosion control for warewashing equipment



Kleenware HTS-11 System: EV9799-11
HT-10 Replacement Cartridge: EV9799-22

BENEFITS

Scale control system features Hydro Blend which inhibits mineral deposits and provides corrosion protection

Extends the life of expensive foodservice equipment

Opaque (red) high temperature bowl allows for hot water (up to 170° F) feed installations

Transparent replacement cartridge containing HydroBlend scale inhibitor, which is effective up to 200° F

Specially designed flow through head assures consistent, predictable product feed rates

INSTALLATION TIPS

The HTS-11 system must be used as a unit (i.e. high temperature bowl, head and cartridge)

Install vertically using the mounting bracket provided

Use 3/4" water line and observe proper inlet/outlet water directions

Some pressure relief mechanism should be provided downstream of the system to permit releasing line pressure when changing cartridges

Delimiting of equipment prior to installation is recommended, but not required

OPERATION TIPS

Inspect HT-10 cartridge at least every 6 months for replacement

Pre-existing equipment scale may be dislodged and settle to the bottom of a chamber which can clog drain initially. Remove any settled scale

In new installations, the HydroBlend usage rate may start high, but will be reduced as existing scale is removed

Replace HT-10 cartridge before HydroBlend™ compound is completely used up

APPLICATION/SIZING

Commercial dishwashers

Commercial glassware washers

Warewashing booster heaters

Kleenware HTS-11 System

SPECIFICATIONS

Overall Dimensions:
12-1/2"H x 4-3/4"W x 4-5/8"D

Inlet connection: 3/4"

Outlet connection: 3/4"

Service Flow Rate:
Maximum 15 gpm (56.8 Lpm)

Pressure Requirements:
10 - 200 psi (0.7 – 13.6 bar), non-shock

Temperature:
Housing: 170°F (77°C)
Scale Inhibition: 200°F (93°C)

No electrical connection required

Shipping Weight: 7 lbs.

Operating Weight: 8 lbs.

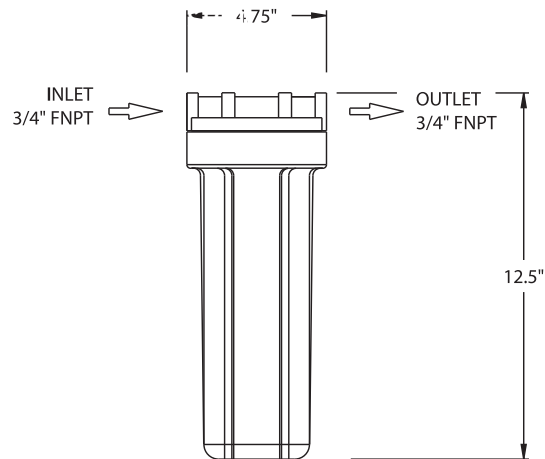

WARRANTY

Everpure water treatment systems (excluding replaceable elements) are covered by a limited warranty against defects in material and workmanship for a period of five years after date of purchase. Everpure replaceable elements (filter cartridges and water treatment cartridges) are covered by a limited warranty against defects in material and workmanship for a period of one year after date of purchase. See printed warranty for details. Everpure will provide a copy of the warranty upon request.

EVERPURE®

Worldwide Headquarters:
EVERPURE, LLC
1040 Muirfield Drive
Hanover Park, Illinois 60133
Toll Free (800) 323-7873
Tel (630) 307-3000
Fax (630) 307-3030
<http://www.everpure.com>

In Europe:
Pentair Water Belgium B.V./B.A.
Industriepark Wolfstee
Toekomstlaan 30
B- 2200 Herentals
BELGIUM
TEL: +32.(0).14.283.500
FAX: +32.(0).14.283.505

In Japan:
Hashimoto MN Bldg. 7F
3-25-1 Hashimoto Sagamihara-Shi
Kanagawa 229-1103
JAPAN
TEL: 81.(0)42.775.3011
FAX: 81.(0)42.775.3015

Everpure, LLC
1040 Muirfield Drive
Hanover Park, IL 60133
Ph: 630-307-3010 Fax: 630-307-3030