

BOWL CUTTERS



MODEL K80

Bowl cutting produces as much as 15% higher finished product yield. Bowl cutting also allows the use of up to 30% more water and results in less shrinkage.

STANDARD

- 2 independent motors (bracket knife and bowl).
- Two 2 speed motors
- 6 knife head and compensating rings to use for 3 -knife head.
- Anti-noise lid
- All stainless steel
- Water resistant switchboard

OPTIONAL

- Optional slow knife mixing speed in 2 directions.
- Extracting arm with motorized disc to unload to a trolley



Front lid

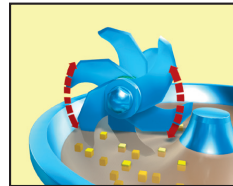

Optional slow knife mixing speed in 2 directions.



Standard removable 6 and 3-knife head.



Optional motorized unloader

SPECIFICATIONS

Model	K80
Bowl Volume	80 L / 21 gal
Mixture Bowl Capacity (approx.)	65 kg./143.3 lbs.
Knife Horsepower	14.3/20.4HP
Knife Speed	2200/4300 RPM
Bowl Horsepower	2/3.4 HP
Bowl Speed	11/21 RPM
Electrical	220V/60/3
Weight	2425 lbs.
Packaging Weight	2860 lbs.
Dimensions (DWH)	57" x 82.3" x 50"
Packaging Dimensions	96" x 66" x 60"
Item #	10880

DIMENSIONS

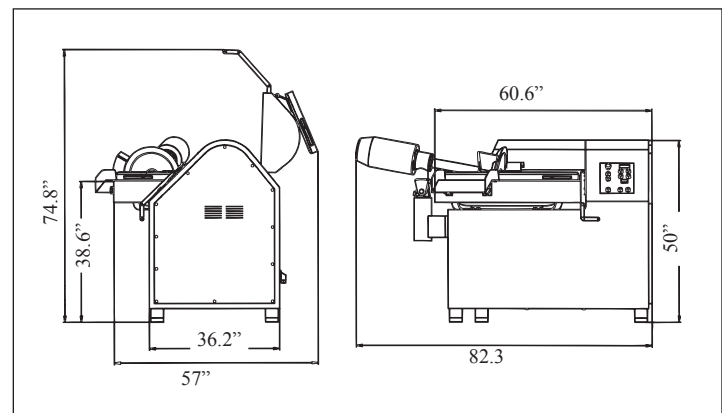

Mississauga, Ontario, Canada

Niagara Falls, New York, USA

Tel: (905) 828-0234 Toll-Free: 1-800-465-0234 Fax: (905) 607-0234 Email: sales@omcan.com

www.omcan.com