

CENTER OF ALL YOUR FOOD SERVICE NEEDS

PYRALIS PIZZA OVENS WITH DOUBLE CHAMBER AND DIGITAL DISPLAY

Item #: 40643

Model #: PE-IT-0049-DD

**WITH
ACTIVESTONE
TECHNOLOGY**

Pyralis ovens have a steel front, pre-painted white grey body, steel door with glass, a knob for opening and closing the steam exhauster and non-thermal handles.



The Activestone

Therographic test show that in a chamber heated by Activestone, the desired temperature can be reached within a shorter time span and heat is distributed evenly.

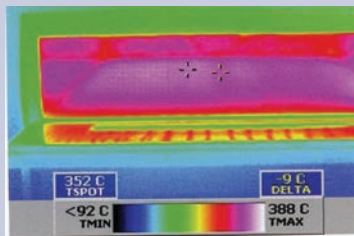
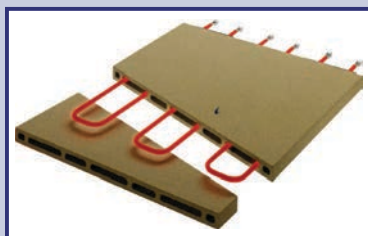

ACTIVESTONE



Authorized Dealer

COOKING EQUIPMENT

PYRALIS PIZZA OVEN WITH DOUBLE CHAMBER AND DIGITAL DISPLAY



Digital display

Features:

The Pyralis is an electric oven that was designed and built to offer extremely high levels of performance, efficiency and reliability with low operating costs. It is available for baking 4 to 18 pizzas with a diameter of 34 cm. The digital version has an electronic card that is used to program the start to end of baking and two work settings (continuous/P2 and non-continuous/P1). The digital Pyralis has a safety thermostat and independent chambers. Upon request, some models can be produced with single-phase voltage.

* *Special Order are available for the following upon request: stainless stands, casters, hoods, vents and suction motor.*



40643

48.7 cu. ft. Pyralis Series Oven with Double Chamber and Digital Display featuring Active Stone

ITEM NUMBER	40643
MODEL	PE-IT-0049-DD
TEMPERATURE	842° F / 450° C
ELECTRICAL	220V / 60 / 3
POWER	18 kW
CHAMBER DIMENSIONS (LxDxH)	(41.3" x 27.6" x 5.9") x 2
EXTERNAL DIMENSIONS (LxDxH)	56.9" x 39.8" x 29.5"
PACKAGING DIMENSIONS (LxDxH)	44" x 57.7" x 33"
VOLUME	48.7 Cu. Ft.
WEIGHT	Net Weight: 231 kg / 508.2 lbs. Gross Weight: 254 kg / 558.8 lbs.

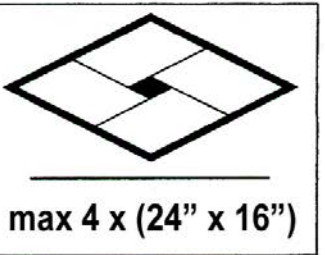
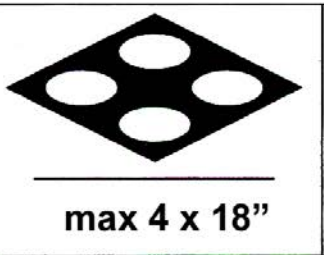
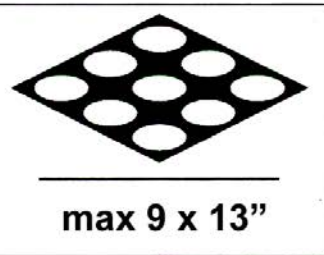
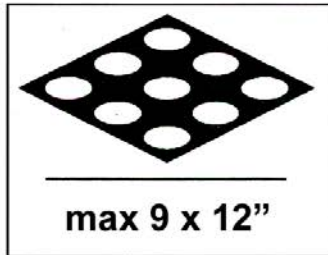
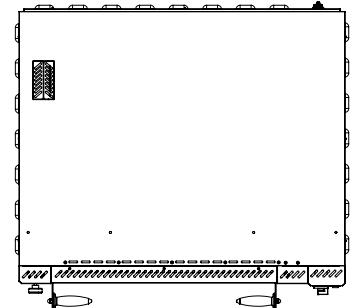
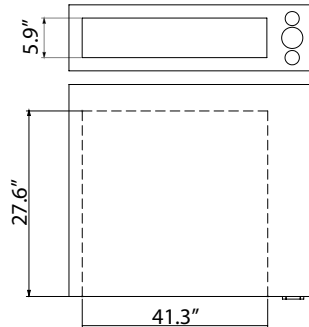
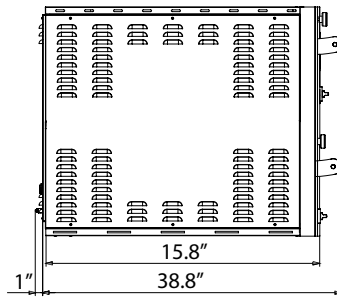
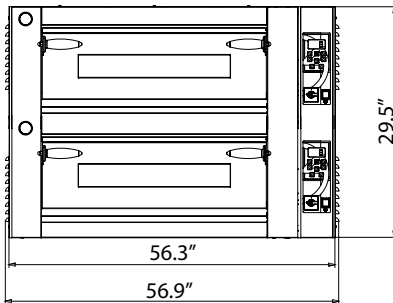

OMCAN INC.

Telephone: 1-800-465-0234
 Fax: (905) 607-0234
 E-mail: sales@omcan.com
 Website: www.omcan.com



Follow us to keep up to date with the latest news and offers

