



*SERVING THE FOOD INDUSTRY SINCE 1951*

## BREAD SLICER WITH 1/2 HP MOTOR

Item: 21122 | Model: SB-TW-0016-S



**SLICE YOUR FRESH-BAKED BREAD EFFICIENTLY**

Save time with Omcan's bread slicer. Perfect for bakeries, sandwich stores, and supermarkets. Powered and equipped with 1/2 HP motor, this machine is safety-protected by an interlocked safety loaf pusher system.



**WARRANTY**  
PARTS AND LABOR

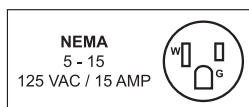

Authorized Dealer

# FOOD EQUIPMENT

BREAD SLICER WITH 1/2 HP MOTOR SB-TW-0016 | 21122



Omcan's SB-TW-0016-S bread slicer is designed for shop counters. A safety guard device is designed especially for protecting the operator. A bread bagging shelf is provided for the operator to pack bread easily. Crumb drawer is fitted for collecting excess crumbs. Heavy duty construction blade frame makes evenly sliced bread.

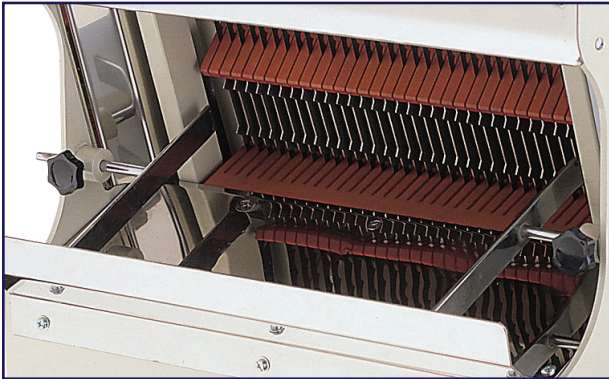

## TECHNICAL DRAWING AND DIMENSIONS

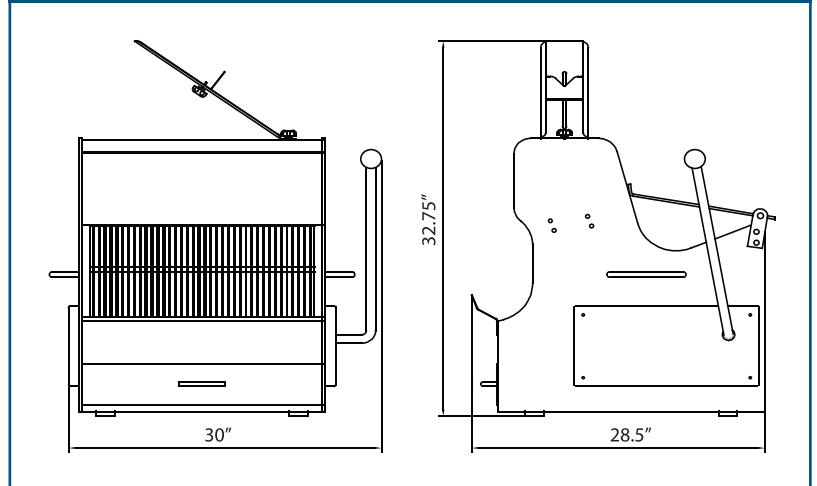

## TECHNICAL SPECIFICATION

ITEM	21122
MODEL	SB-TW-0016-S
QUANTITY OF SLICING BLADES	26
SLICE THICKNESS (MM/IN)	16 mm / 5/8"
MAXIMUM LOAF LENGTH	15"
MOTOR	1/2 HP / 0.375 Kw
ELECTRICAL	120V/60Hz/1Ph
AMPS	8A
WEIGHT	115 kgs. / 253.5 lbs.
DIMENSIONS (DWH)	28.5" x 30" x 32.75" 724 x 762 x 832 mm
ADDITIONAL INFORMATION	In compliance with Province of Quebec safety standards



**WARRANTY**  
PARTS AND LABOR

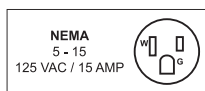

## OMCAN INC.

Telephone: 1-800-465-0234  
Fax: (905) 607-0234  
Email: sales@omcan.com  
Website: www.omcan.com



Follow us to keep up to date with the latest news and offers



2015.E.O.E