



FOOD EQUIPMENT

SERVING THE FOOD INDUSTRY SINCE 1951

BOWL PROCESSORS

Item: 23545
Model: FP-CN-0006

Item: 23546
Model: FP-CN-0009



6L Bowl Processor
Item 23545

9L Bowl Processor
Item 23546



**LIMITED
WARRANTY**
PARTS AND LABOR



Authorized Dealer

FEATURES:

- Made of high quality stainless steel with polished surface
- Equipped with a 1-HP motor with adjustable speed
- 4Cr13 stainless steel made knife
- Comes with a safety switch
- Stainless steel bowl
- Easy to clean
- High speed 2,800 RPM, adjustable to 1100 RPM
- Easily cuts meat, fish, vegetables, fruits, nuts and even cheese into pieces



4Cr13 stainless steel knife provides excellent resistance to corrosion and hot oxidation

COMPONENTS:

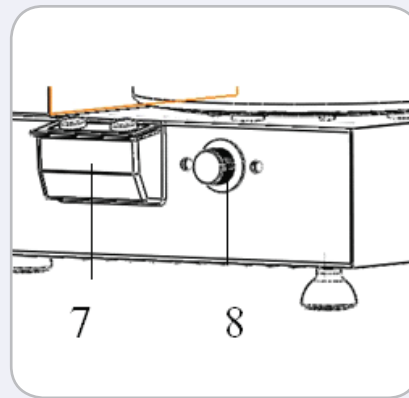
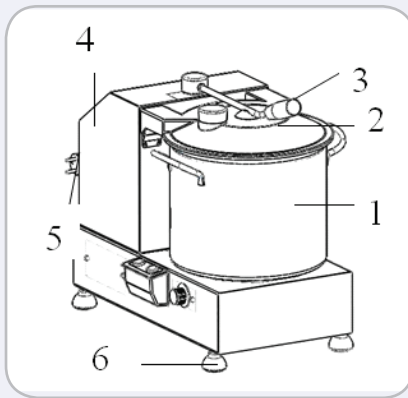

1. Container
2. Cover
3. Arm lock
4. Main body
5. Power cable
6. Feet
7. Control panel
8. Knob for controlling speed

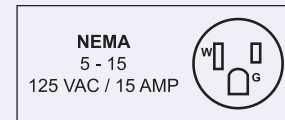

TECHNICAL SPECIFICATIONS

	BOWL PROCESSOR WITH 6-L CAPACITY	BOWL PROCESSOR WITH 9-L CAPACITY
ITEM NUMBER	23545	23546
MODEL	FP-CN-0006	FP-CN-0009
POWER	1 HP / 0.75 kW	1 HP / 0.75 kW
CAPACITY	4.22 - 6.35 QT / 4 - 6 L	6.35 - 9.50 QT / 6 - 9 L
ELECTRICAL	110V/60Hz/1	110V/60Hz/1
RPM	1100 - 2800	1100 - 2800
WEIGHT	42 lbs./ 19 kg.	44 lbs./ 20 kg.
PACKAGING WEIGHT	46 lbs./ 21 kg	49 lbs./ 22 kg
DIMENSIONS (DWH)	15" x 11" x 15" / 381 x 279 x 381 mm	18.50" x 11.41" x 17" / 470 x 290 x 432 mm
PACKAGING DIMENSIONS	18" x 23" x 15" / 457 x 584 x 381 mm	19" x 23" x 16" / 482.6 x 584 x 406.4 mm

OMCAN INC.

Telephone: 1-800-465-0234
 Fax: (905) 607-0234
 Email: sales@omcan.com
 Website: www.omcan.com



Follow us to keep up to date with the latest news and offers

