



REFRIGERATION

**COUNTERTOP REFRIGERATED SHOWCASE -
100L CAPACITY**

Item #: 27155

Model: RS-CN-0100-E



Authorized Dealer

REFRIGERATION

COUNTERTOP REFRIGERATED SHOWCASE -
100L CAPACITY



- Comes with rear sliding doors, interior light, and glass windows on each side

- Designed to fit on table tops
- CE Certified

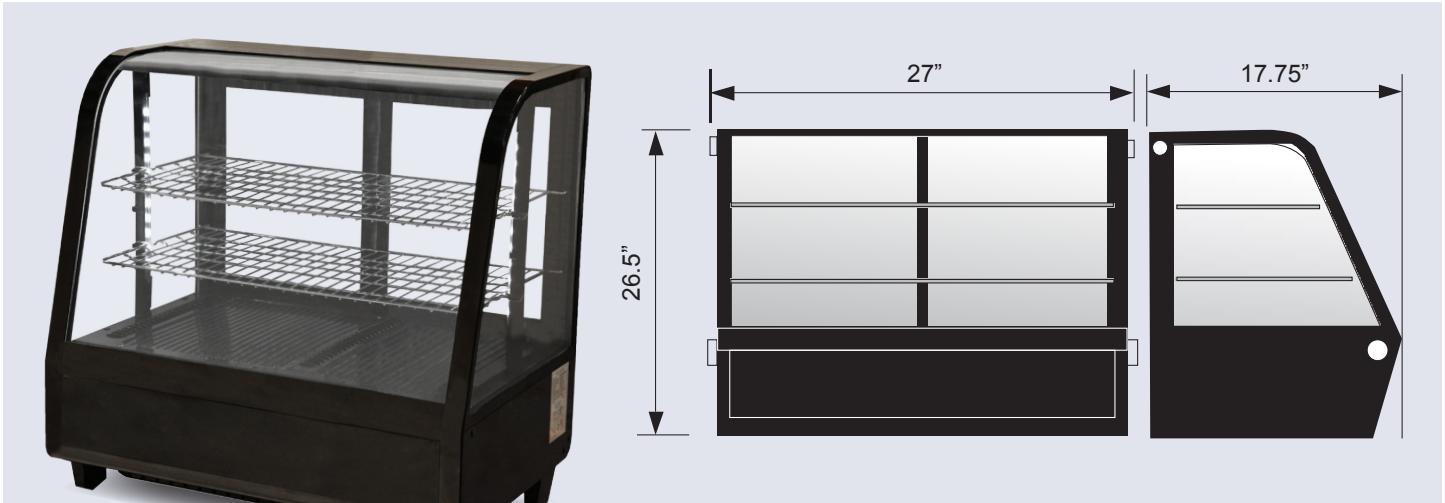

TECHNICAL SPECIFICATION

ITEM NUMBER	27155
MODEL	RS-CN-0100-E
CAPACITY (L/ CU. FT.)	100 L / 3.5 cu. ft.
RACK SIZE	12.25" x 24" 31cm x 61cm
TEMPERATURE	0° ~ 12°C / 32° ~ 53.5°F
POWER INPUT	160W
REFRIGERANT	R-134A
ELECTRICAL	110V / 60 / 1
DIMENSIONS (WDH)	27" x 17.75" x 26.5" 69cm x 45cm x 67cm
PACKAGING DIMENSIONS (WDH)	30" x 21" x 30" 76cm x 53cm x 76cm
WEIGHT	70 lbs./ 32kg
PACKAGING WEIGHT	94 lbs./ 43kg

OMCAN INC.

Telephone: 1-800-465-0234
Fax: (905) 607-0234
E-mail: sales@omcan.com
Website: www.omcan.com



Follow us to keep up to date with the latest news and offers

