



**BROILER**

**SERVING THE FOOD INDUSTRY SINCE 1951**

## **QUARTZ ADJUSTABLE DOUBLE SALAMANDER**

**Item: 39582**

**Model: CE-CN-1633-D**



*High Performance  
and Quality  
Double Salamander*



Authorized Dealer

# COOKING EQUIPMENT

## ADJUSTABLE DOUBLE SALAMANDER



### Detail Shots

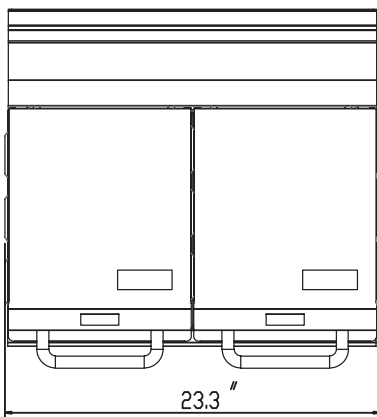

TOP VIEW

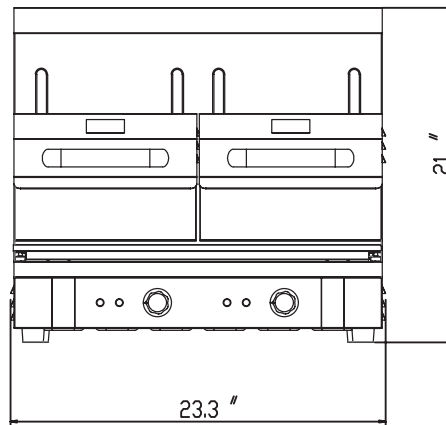

FRONT VIEW

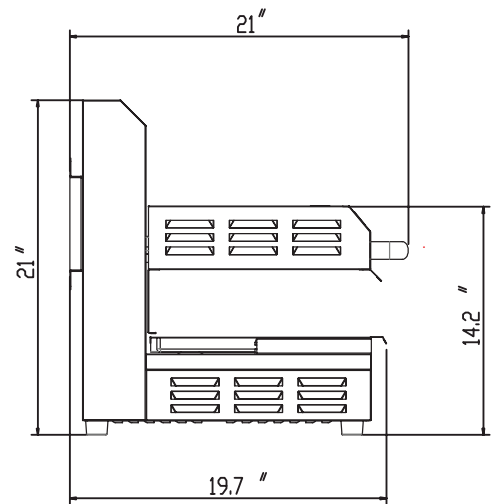

SIDE VIEW

### Features:

- Quick quartz heating from top
- Adjustable top grill for quick cooking with minimal heat loss
- Removable base tray
- Rubber feet
- Wall mounted available
- Adjustable heating supply
- Built with stainless steel

Ideal for heating, baking, cooking pizzas, sandwiches, cakes and much more. It distributes heat evenly for great cooking results.

### PRODUCT SPECIFICATIONS

ITEM	39582	WEIGHT	42 Kg/ 92.6 lbs
MODEL	CE-CN-1633-D	PACKAGING WEIGHT	44.5 Kg/ 98 lbs
MATERIAL	Stainless Steel	DIMENSIONS (DWH)	21" x 23.3" x 21" / 533 x 592 x 533 mm
WARMING BASE	22.8" x 14" / 580 x 355 mm	PACKAGING DIMENSIONS	22.4" x 24.8" x 22.4" / 570 x 630 x 570mm
POWER	3200 W		
ELECTRICAL	240V / 60 Hz		

### OMCAN INC.

Telephone: 1-800-465-0234  
 Fax: (905) 607-0234  
 E-mail: sales@omcan.com  
 Website: www.omcan.com



Follow us to keep up to date with the latest news and offers

