



FOOD EQUIPMENT

SERVING THE FOOD INDUSTRY SINCE 1951

COUNTER TOP ELECTRIC GRIDDLE

ITEM: 20179 MODEL: CE-CN-1800-G

GET YOUR MEALS COOKING AND TASTING GREAT IN NO TIME

Omcan's Counter Top Electric Griddle is made up of durable stainless steel construction that is suitable for commercial use. Designed to be safe and energy efficient. Features independent thermostat controls for convenient use.



WARRANTY
PARTS AND LABOR

NEMA
5 - 20
125 VAC / 20 AMP



SHIPPED ON PALLET



Authorized Dealer

FOOD EQUIPMENT

COUNTER TOP ELECTRIC GRIDDLE CE-CN-1800-G



TECHNICAL DRAWING AND DIMENSIONS

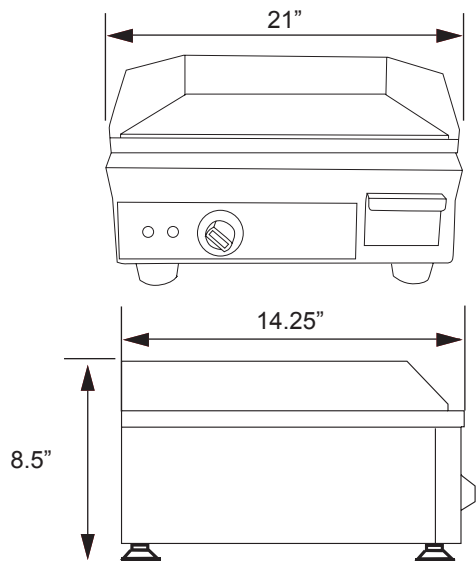

FEATURES

- Stainless steel finish
- Removable drip pan for easy cleaning
- Even-Heating Surface
- Temperature Range: 60° - 300°C / 140° - 572°F
- Independent thermostat controls for convenient use

TECHNICAL SPECIFICATION

ITEM NUMBER	20179
MODEL	CE-CN-1800-G
POWER	1.8 kW
TEMPERATURE RANGE	60°C - 300°C / 140°F - 572°F
COOKING AREA	14" x 16" / 355.6 x 406.4 mm
ELECTRICAL	120V / 60Hz / 1Ph
WEIGHT	20 kg. / 44 lbs.
PACKAGING WEIGHT	23 kg. / 51 lbs.
DIMENSIONS (DWH)	14.25" x 21" x 8.5" / 362 x 533 x 216 mm
PACKAGING DIMENSIONS	14" x 24" x 18" / 356 x 610 x 457 mm



WARRANTY
PARTS AND LABOR

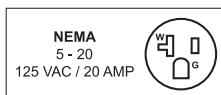

OMCAN INC.

Telephone: 1-800-465-0234

Fax: (905) 607-0234

Email: sales@omcan.com

Website: www.omcan.com



Follow us to keep up to date with the latest news and offers



2015.E.O.E