



FOOD EQUIPMENT

SERVING THE FOOD INDUSTRY SINCE 1951

STAINLESS STEEL COUNTERTOP REVERSIBLE DOUGH SHEETER

Item: 42154 Model: BE-CN-2083-CSS

EFFICIENT EQUIPMENT PERFECT FOR YOUR BAKERY

Suitable for bakeries, restaurants, and hotels, Omcan's dough sheeter is designed for optimal performance. Equipped with safety features, preset roller thickness controls, and foldable tables for space saving storage, this machine increases your bakery's production and efficiency. Safe to operate and easy to clean.



**LIMITED
WARRANTY**
PARTS AND LABOR



Authorized Dealer

FOOD EQUIPMENT

STAINLESS STEEL COUNTERTOP REVERSIBLE DOUGH SHEETER



DIMENSIONS

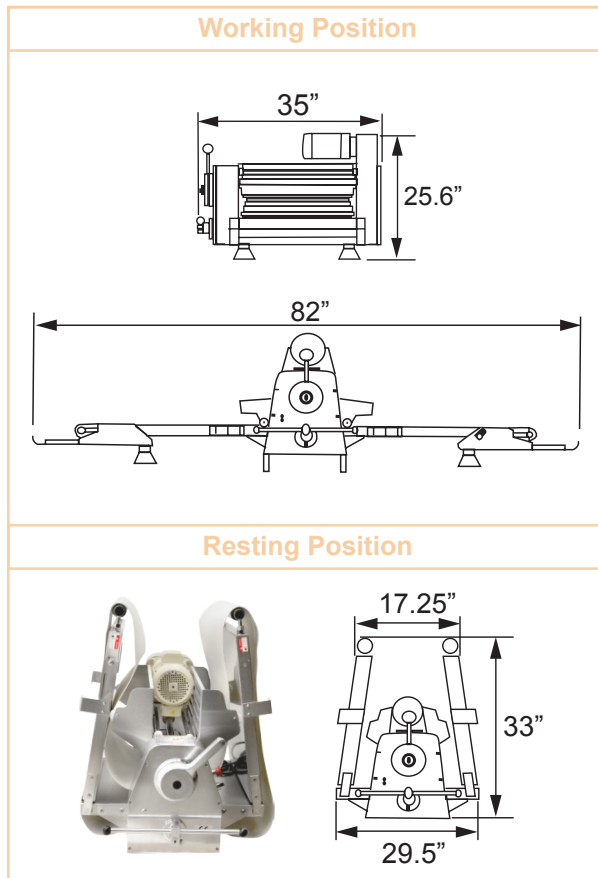

FEATURES

- Made of high quality stainless steel; ideal use for long period of time
- Fixed conveyor speed
- Roller adjustments are manual
- Suitable for bakeries, restaurants, and hotels
- Equipped with preset roller thickness control and foldable tables for space-saving storage
- Safety features: safety guards, emergency stop switch, thermal overload device



TECHNICAL SPECIFICATION

ITEM NUMBER	42154	CONVEYER WIDTH	22.5" / 571.5 mm
MODEL	BE-CN-2083-CSS	CONVEYER BELT SPEED	18m/min - 32m/min
DESCRIPTION	Countertop dough sheeter, stainless steel	ROLLER SPEED	124r/min
ELECTRICAL	220 V / 60 Hz / 1 Ph	MAXIMUM DOUGH CAPACITY	5 kg / 11 lbs.
POWER	0.5 HP / 0.37 kW	WORKING POSITION DIMENSION (DWH)	35" x 82" x 25.6" / 880 x 2080 x 650mm
ROLLER SIZE	3.5" / 88mm (Dia.), 20.5" / 520mm (W)	RESTING POSITION DIMENSION (WH)	29.5" x 33" / 749 x 838 mm
ROLLER ADJUSTABLE GAP	1-1.4" / 1 - 35 mm	WEIGHT	125 kg / 275.6lb.
CONVEYER BELT WIDTH	19.75" / 501.7 mm	GROSS WEIGHT	155 kg. / 341 lbs.
		GROSS DIMENSION	37" x 29" x 40" / 940 x 736.6 x 1016 mm

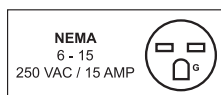

OMCAN INC.

Telephone: 1-800-465-0234
 Fax: (905) 607-0234
 Email: sales@omcan.com
 Website: www.omcan.com



Follow us to keep up to date with the latest news and offers

