



Horizon Elite™

self-contained 1010, 1410 series Chewblet® ice machine

Short form specification:

Ice machine to be a Follett® Horizon Elite ice machine model _____ [Insert size/series, condenser type and installation/mounting, from model number guide] capable of producing compressed nugget ice using an efficient, sanitary horizontal evaporator/auger system and delivering ice by a flexible wire reinforced transport tube to □ ice storage bin, □ ice and water dispenser, □ ice and beverage dispenser, □ drop-in dispenser or □ Ice Manager™ diverter valve system, slide-out compressor/condenser/evaporator with utility docking station, front-mounted unit status display, evaporator water inlet at harvest end with automatic flush while producing ice, and semi-automatic cleaning and sanitizing system, plus all the features listed below and mounting/performance-enhancing accessories checked.

Features

Horizon Elite

- 1010 series - up to 1061 lb (482 kg) in 24 hours
- 1410 series - up to 1466 lb (665 kg) in 24 hours
- automatically transport ice through a tube with RIDE® technology from up to 75' (22.8 m) away
- chewable, compressed nugget ice is preferred over cubes¹
- Chewblet ice dispenses reliably from ice and beverage dispensers
- available with approximately 1.00" (2.54 cm) long standard Chewblet ice or optional 3/8" (0.95 cm) long Micro Chewblet™ ice
- quiet production without noisy harvest cycles

Revolutionary, scale inhibiting design

- produces ice that has 15% the TDS of the incoming water for optimum dispensing and long life in drinks
- quarantines and regularly expels scale producing dissolved solids to dramatically reduce scale buildup
- increases time between descaling and reduces or eliminates the need for expensive scale treatment
- saves 35% water compared to comparable cubers
- meets 2018 Department of Energy regulations

Durable, attractive ice machine

- regular bearing inspection or replacement is not required
- upgraded, easy-to-read LED operating status and diagnostic display

Designed with sanitation in mind

- Agion® silver-based antimicrobial product protection of key ice and water contact components²
- floatless, sealed design inhibits formation of biofilms
- semi-automatic cleaning and sanitizing system

Warranty

- 3 years parts and labor, 5 years compressor parts

Certifications



Model configurations					
For use with ¹	Install/mount	Condenser	V/Hz/Ph	Item number ⁴ 1010 series	Item number ⁴ 1410 series
ice storage bin	top mount	air	208-230/60/1	HCC1010ABT	HCC1410ABT
			230/50/1	HCE1010ABT	HCE1410ABT
		water	208-230/60/1	HCC1010WBT	HCC1410WBT
			230/50/1	HCE1010WBT	HCE1410WBT
	RIDE	air	208-230/60/1	HCC1010ABS	HCC1410ABS
			230/50/1	HCE1010ABS	HCE1410ABS
water		208-230/60/1	HCC1010WBS	HCC1410WBS	
		230/50/1	HCE1010WBS	HCE1410WBS	
Follett Vision™ undercounter ice & beverage dispenser	RIDE	air	208-230/60/1	HCC1010AVS	HCC1410AVS
			230/50/1	HCE1010AVS	HCE1410AVS
		water	208-230/60/1	HCC1010WVS	HCC1410WVS
			230/50/1	HCE1010WVS	HCE1410WVS
Cornelius PR150 undercounter ice & beverage dispenser ²	RIDE	air	208-230/60/1	HCC1010APS	HCC1410APS
		water	208-230/60/1	HCC1010WPS	HCC1410WPS
countertop ice & beverage dispenser (by others)	top mount ³	air	208-230/60/1	HCC1010AHT	HCC1410AHT
			230/50/1	HCE1010AHT	HCE1410AHT
		water	208-230/60/1	HCC1010WHT	HCC1410WHT
			230/50/1	HCE1010WHT	HCE1410WHT
	RIDE	air	208-230/60/1	HCC1010AHS	HCC1410AHS
			230/50/1	HCE1010AHS	HCE1410AHS
water	208-230/60/1	HCC1010WHS	HCC1410WHS		
	230/50/1	HCE1010WHS	HCE1410WHS		
drop-in dispenser (by others)	RIDE	air	208-230/60/1	HCC1010AJS	HCC1410AJS
			230/50/1	HCE1010AJS	HCE1410AJS
		water	208-230/60/1	HCC1010WJS	HCC1410WJS
			230/50/1	HCE1010WJS	HCE1410WJS
Ice Manager diverter valve system	RIDE	air	208-230/60/1	HCC1010AMS	HCC1410AMS
		water	220/60/1	HCC1010WMS	HCC1410WMS

¹ Ordered separately.

² Not compatible with Micro Chewblet ice.

³ Requires top kit (see page 4 for item number).

⁴ For Micro Chewblet ice, replace second character (C) with an M e.g. HMC1010ABT.

Job _____

Item _____

Accessories

- Top kit for ice and beverage dispensers (listed on page 4)
- Water filters (refer to form# 9905)
- Wall mount bracket (item# 01085455)
- Ice machine stand, height-adjustable (item# 01085463)
- Timer to control one or two ice machines (item# 00967265)
- Longer ice transport tube, specify length: ___ ft/m in 5'/1.5 m increments (10'/3 m provided as standard for RIDE models) (item# 00174896)
- SafeCLEAN Plus™ ice machine cleaner
 - 1 x 8 oz (237 ml) bottle (item# 01147826)
 - 6 x 8 oz (237 ml) bottles (item# 01149954)
 - Carton of 24 x 8 oz (237 ml) bottles (item# 01149962)
- SaniSponge™, 24 sanitary sponges (item# 01075431)

Dimensional drawing

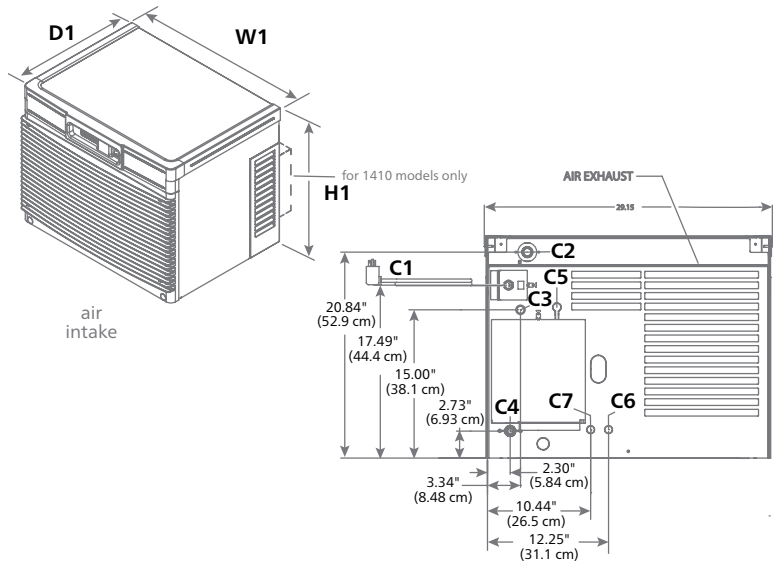

Specification

	Horizon Elite 1010 series	Horizon Elite 1410 series
W1 Width	29.15" (74.0 cm)	29.15" (74.0 cm)
D1 Depth	23.25" (59.1 cm)	25.15" (63.9 cm)
H1 Height	22.50" (57.2 cm)	22.50" (57.2 cm)
Clearance	top, left and right – 1.00" (2.54 cm)	top, left and right – 1.00" (2.54 cm)
Electrical (HCC models) 208-230 V/60/1	C1 11 amps, requires dedicated 15 amp circuit, 6' (1.8 m) cord, NEMA 6-15 plug	C1 14 amps, requires dedicated 20 amp circuit, 6' (1.8 m) cord, NEMA 6-20 plug
Electrical (HCE models) 230 V/50/1	C1 11 amps, requires dedicated 15 amp circuit, 6' (1.8 m) cord only, no plug	C1 14 amps, requires dedicated 20 amp circuit, 6' (1.8 m) cord only, no plug
Operating power	2.4 kW	3.1 kW
C2 Ice transport tube	see page 8 for details	see page 8 for details
C3 Water inlet	3/8" OD push-in water inlet – internal connection	3/8" OD push-in water inlet – internal connection
C4 Drain	3/4" MPT, 1" drain required. See page 7 for details.	3/4" MPT, 1" drain required. See page 7 for details.
C5 Ice bin signal cord	for Vision applications only	for Vision applications only
Water-cooled ice machine connections	C6 – 1/4" FPT condenser inlet C7 – 1/4" FPT condenser outlet	C6 – 1/4" FPT condenser inlet C7 – 1/4" FPT condenser outlet
Air temperature	50 - 100 F (10 - 38 C)	50 - 100 F (10 - 38 C)
Water temperature	45 - 90 F (7 - 32 C)	45 - 90 F (7 - 32 C)
Potable water pressure	10 - 70 psi (69 - 483 kPa)	10 - 70 psi (69 - 483 kPa)
Condenser water pressure	30 - 150 psi (207-1034 kPa)	30 - 150 psi (207-1034 kPa)
Ice production	60 Hz models and 50 Hz water-cooled models see page 8 50 Hz air-cooled models at 70 F (21 C) air, 50 F (10 C) water – 865 lb (393 kg) 50 Hz air-cooled models at 90 F (32 C) air, 70 F (21 C) water – 734 lb (333 kg)	60 Hz and 50 Hz models see page 8
Energy consumption 90 F (32 C) air, 70 F (21 C) water	air-cooled models – 4.80 kWh water-cooled models – 4.20 kWh per 100 lb (45.4 kg) ice	air-cooled models – 4.84 kWh water-cooled models – 3.80 kWh per 100 lb (45.4 kg) ice
Heat rejection	air-cooled models – 11,300 BTU/hr (2,849 Kcal/hr) water-cooled models – 12,800 BTU/hr (3,228 Kcal/hr)	air-cooled models – 16,000 BTU/hr (4,035 Kcal/hr) water-cooled models – 16,400 BTU/hr (4,135 Kcal/hr)
Water consumption	12.0 gal (45 L) of potable water per 100 lb (45.4 kg) of ice (per AHRI test standards). 12.4 gal (46.9 L) at low TDS flush setting.	12.0 gal (45 L) of potable water per 100 lb (45.4 kg) of ice (per AHRI test standards). 12.3 gal (46.5 L) at low TDS flush setting.
Water flow requirement for water-cooled models	1 gallon per minute	1 gallon per minute
Refrigerant	R404a for 60 Hz models and 50 Hz water-cooled models R449a for 50 Hz air-cooled models	R404a for 60 Hz and 50 Hz models
Approximate ship weight	275 lb (125 kg)	305 lb (138 kg)
Approximate net weight	265 lb (120 kg)	295 lb (134 kg)

1 – Locating the ice machine

Horizon Elite self-contained Chewblet ice machines allow top-mounting or mounting in a base cabinet, on a wall or on a floor stand up to 75' (22.8 m) from the dispenser or ice bin with RIDE technology. In-cabinet mounting (RIDE applications) require special attention to service access, unit ventilation and ice tube runs (see pages 4-8).

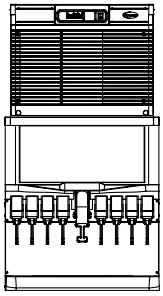
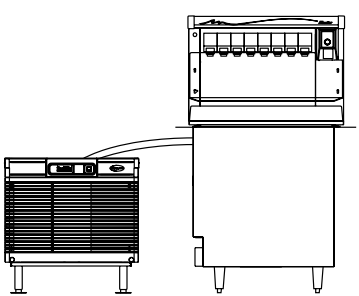
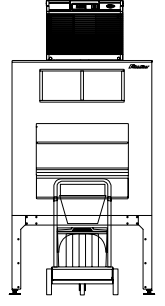
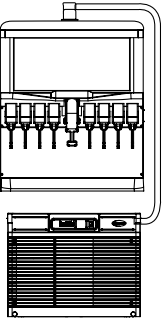
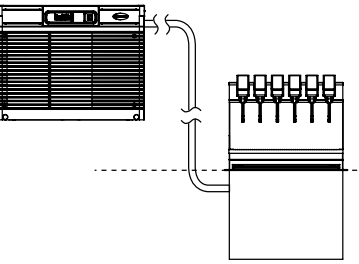
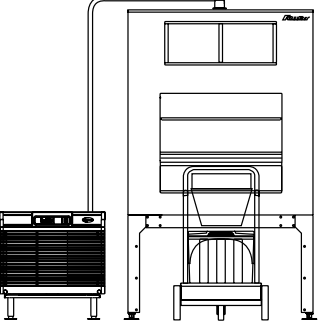
<p>Top mounting – ice and beverage dispensers (by others)</p>	<p>RIDE model – Follett low-profile Vision and Cornelius PR150 ice and beverage dispensers</p>	<p>Top mount on Follett ice storage bins</p>
		
<p>Important specifier notes</p> <ol style="list-style-type: none"> 1. Dispenser must be compatible with nugget ice. See page 4 for compatible ice and beverage dispenser models and top kit numbers. 2. Verify ceiling or soffit height to ensure sufficient top clearance. 	<p>Important specifier notes</p> <ol style="list-style-type: none"> 1. See page 4-6 for critical clearance and venting requirements. 2. Ice transport tube ships with Vision ice and beverage dispenser (Vision applications only). 3. Ice transport tube ships with Horizon Elite ice machine for Cornelius dispensers. 	<p>Important specifier notes</p> <ol style="list-style-type: none"> 1. See form# B300 for bin sizing. 2. Verify ceiling or soffit height to ensure top clearance. 3. Locate floor sink or grate and drains in front of storage bin. 4. Do not position bin drain lines to block Ice•Device™ bin cart.
<p>RIDE model – ice and beverage dispensers (by others)</p>	<p>RIDE model – drop-in beverage dispensers (by others)</p>	<p>RIDE model – Follett ice storage bins</p>
		
<p>Important specifier notes</p> <ol style="list-style-type: none"> 1. Dispenser must be compatible with nugget ice. Compatible dispensers include Coca-Cola Freestyle 9000, Cornelius DB/ID/DF150/175, Lancer 4500-22N, FS-16N, FS-22N and FS-44N, Servend MD150/175/200/250, SV175/200/250, MDH-402 and Follett Symphony Plus™ 110CM, as well as dispensers listed on page 4. 2. Top kit MSF30SC required with Coca-Cola Freestyle 7000. Top adapter 46412 and ice kit 46430 must also be ordered from Coca-Cola. Top kit HSF26SC required with Coca-Cola Freestyle 9100. Consult with Coca-Cola and Follett to qualify application prior to ordering. 3. RIDE application is approved only for Pepsi Spire 3.0, 5.0 and 4.1 designed for top mount ice machines and requires MSP24SC for 3.0 and MSP30SC for 5.0 and 4.1, ordered separately. For manual fill versions of Pepsi Spire 3.0, 5.0 and 4.1, contact factory. 4. See page 4-6 for critical clearance and venting requirements. 	<p>Important specifier notes</p> <ol style="list-style-type: none"> 1. Compatible with the following dispensers: Cornelius 1522, 1722, 2323, and Lancer 2200, 2300, 23300. 2. Require 12.00" (30.5 cm) of access space for installation on transport tube side. 3. See page 4-6 for critical clearance requirements. 	<p>Important specifier notes</p> <ol style="list-style-type: none"> 1. See form# B300 for bin sizing. 2. Locate floor sink or grate and drains in front of storage bin. 3. Do not position bin drain lines to block Ice•Device bin cart.

1 – Locating the ice machine (continued)

Top mounting – compatible ice and beverage dispensers ¹					
Manufacturer	Model number	Width in (cm)	Depth ² in (cm)	Height ³ in (cm)	Top kit
Coca-Cola dispensers	Freestyle 7000	30.10 (76.5)	33.11 (84.1)	47.00 (119.38)	H30F30-F ^{4,5}
Cornelius dispensers	DB/ED/DF 200 series	30.00 (76.2)	30.00 (76.2)	34.38 (87.3)	H30C30-F
	DB/ED/DF 250 series	30.00 (76.2)	30.00 (76.2)	38.38 (97.5)	H30C30-F
	DB/ED/DF 300 series	44.00 (111.8)	30.00 (76.2)	34.00 (86.4)	H30C44-(F or B) ⁶
	FlavorFusion / Overload	30.00 (76.2)	30.70 (78.0)	39.38 (100.0)	H30C30-F-FF
	IDC215	30.00 (76.2)	30.70 (78.0)	39.38 (100.0)	H30C30-F-IDC
	IDC255 and Pro Fast Gate	30.00 (76.2)	30.70 (78.0)	36.38 (92.4)	H30C30-F-IDC ⁷
Lancer dispensers	4500-30N	30.00 (76.2)	30.50 (77.5)	36.50 (92.7)	H30L30-F
	FS-30N	30.00 (76.2)	30.50 (77.5)	42.13 (107.0)	H30L30-F
	Beverity	30.00 (76.2)	31.00 (78.7)	37.75 (95.9)	H22L30-F-STP
	Sensation 30"	30.00 (76.2)	31.00 (78.7)	38.25 (97.2)	H30L30-F-STP
	Sensation 44"	44.00 (111.8)	31.00 (78.7)	39.38 (100.0)	H22L44-F-STP
	Touchpoint	32.50 (82.6)	33.70 (85.6)	40.00 (101.6)	H30L30-F-STP
Pepsi dispensers	Spire 5.0 / 4.1	30.50 (77.5)	36.00 (91.4)	42.75 (108.6)	H30P30-F
Servend dispensers	MDH-302	42.80 (108.7)	31.00 (78.7)	32.38 (82.2)	H30S44-(F or B) ⁶

¹All approved dispensers can be filled with a RIDE model Horizon Elite ice machine without a top kit except for Coca-Cola Freestyle 7000 and Pepsi Spire 3.0, 5.0 and 4.1, see page 3 for details.

²Requires minimum 1.00" (2.54 cm) clearance between back of dispenser and wall.

³Net height after installation of top kit (excluding height of ice machine).

⁴Consult with Coca-Cola and Follett to qualify application prior to ordering.

⁵Top adapter 46412 and ice kit 46430 must also be ordered from Coca-Cola.

⁶Specify "F" for front facing, or "B" for backward facing units.

⁷Contact factory regarding IDC Pro.

2 – Undercounter/in-cabinet mounting

Cabinet details	
<p>Important specifier notes</p> <ol style="list-style-type: none"> 1. Cabinet door opening must meet minimum size requirements shown and be free of obstructions to allow ice machine to slide out (no lip or utilities to block removal). 2. Cabinet base must be capable of supporting ice machine and allow ice machine to rest flat on cabinet bottom. 3. No counter supports, electric or plumbing can run in front of the ice machine. 	<p>Cabinet door opening 1010/1410 series models require 1.00" (2.54 cm) all around, 31.00"W x 23.5"H (78.7 cm x 59.69 cm) minimum</p> <p>slides out</p> <p>Cabinet base must be flat and free of obstructions (no lip or utilities to block removal)</p>

3 – Undercounter/in-cabinet mounting and ventilation

Using Follett supplied grilles

Horizon Elite ice machines can be installed undercounter/in-cabinet to fill bins or dispensers using RIDE technology. Care must be taken to ensure proper cabinet venting to avoid recirculation of hot air. Improper venting can cause ice machine outages.

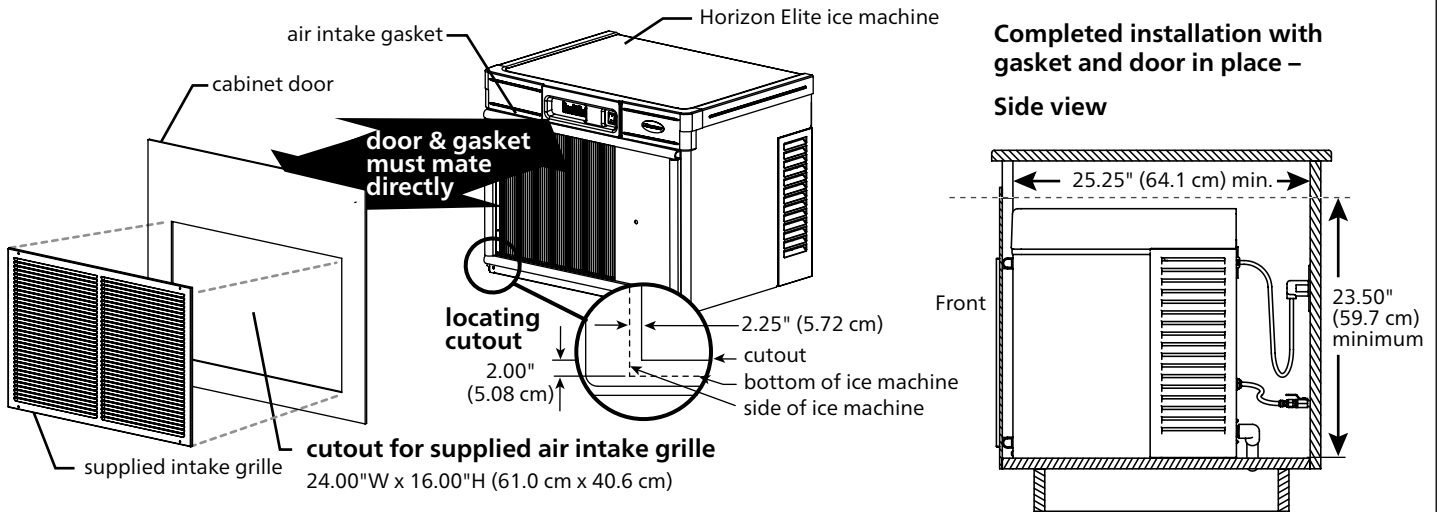
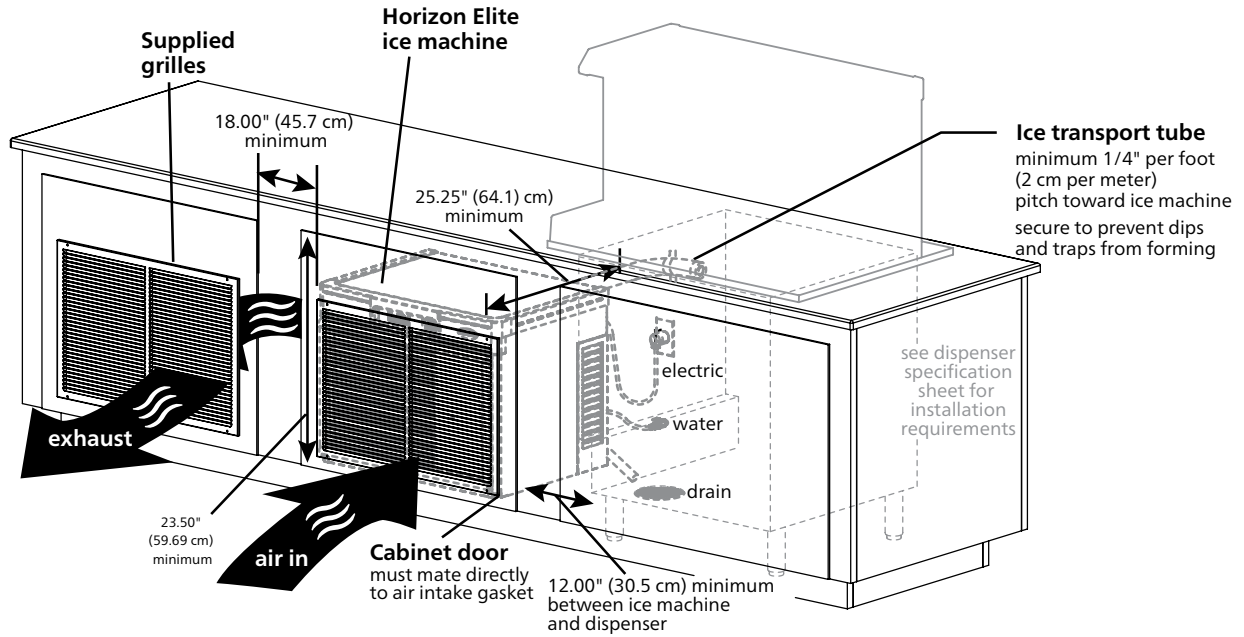

Important specifier notes for using Follett supplied grilles

1. The supplied exhaust grille must be located at least 18.00" (45.7 cm) from the supplied air intake grille (exhaust air must not recirculate with intake air).
2. Cabinet interior must be open to allow for unrestricted exhaust air flow.
3. Ice transport tube needs minimum 1/4" per foot (2 cm per meter) pitch toward ice machine and should be secured to prevent dips and traps from forming.
4. Cabinet door must mate directly to air intake gasket.
5. Cabinet interior must provide a minimum clear space of 23.50" (59.7 cm) high by 25.25" (64.1 cm) deep.
6. Cutout for supplied grilles must meet minimum size requirements shown above.
7. Utilities should be conveniently located as shown.

3 – Undercounter/in-cabinet mounting and ventilation (continued)

Using grilles by others/alternate cabinet ventilation

Cabinets with ventilation or louvers other than those provided require special consideration to provide proper ventilation. Recirculation of hot air will reduce ice machine performance and can cause ice machine outages.

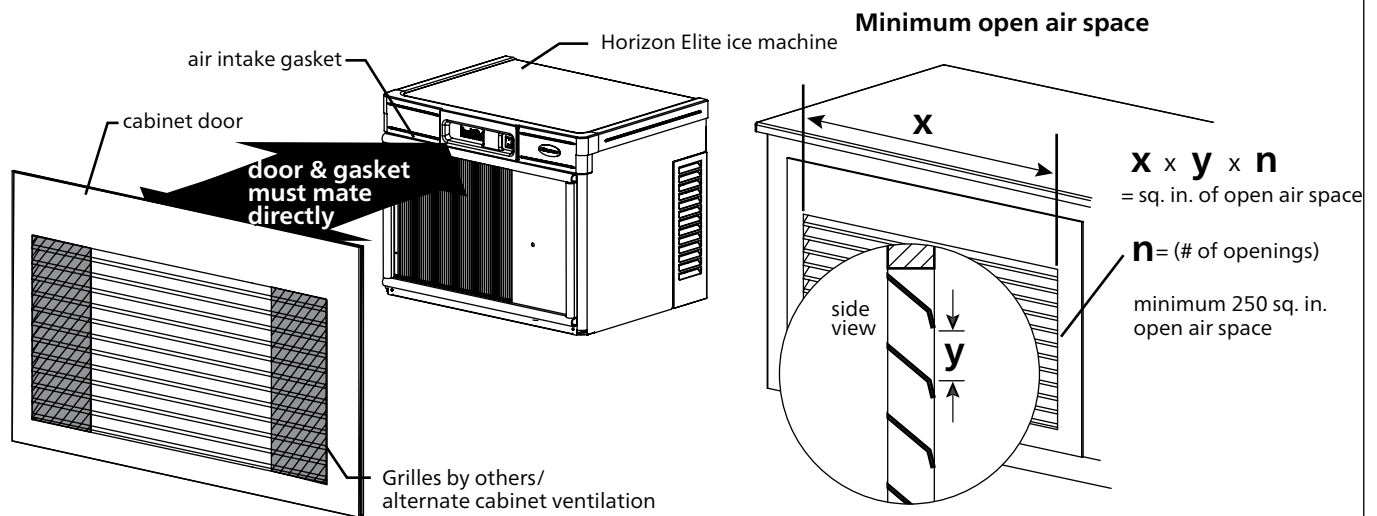
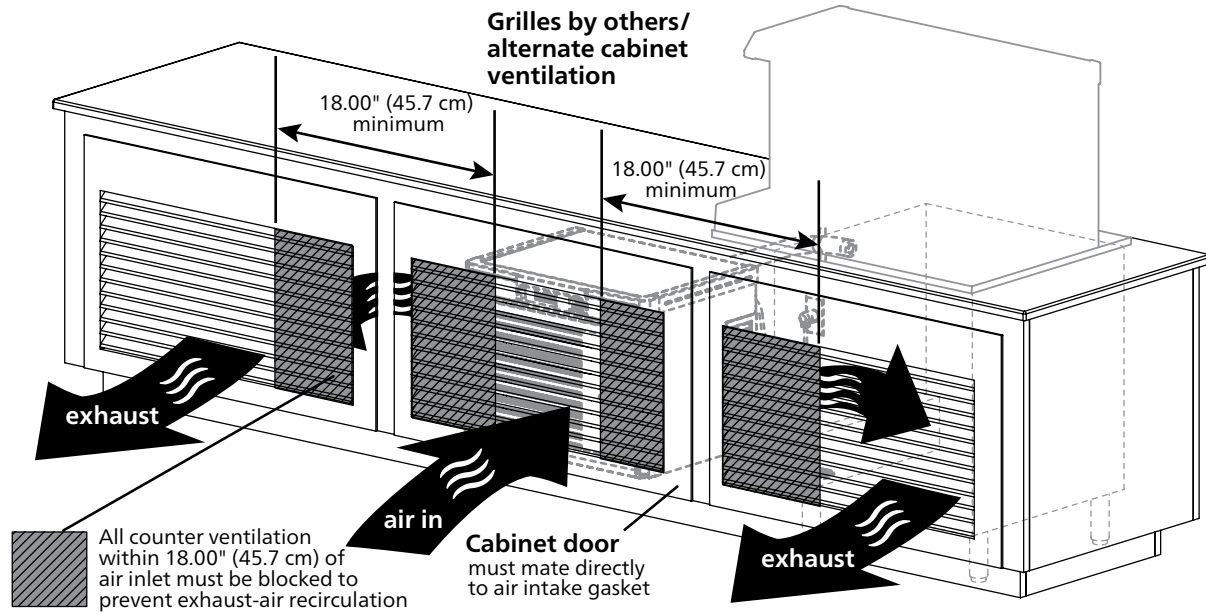

Important specifier notes for using grilles supplied by others/alternate cabinet ventilation

1. Exhaust must be at least 18.00" (45.7 cm) from air intake (exhaust air must not recirculate with intake air).
2. Cabinet interior must be open to allow for unrestricted exhaust air flow.
3. Ice transport tube needs minimum 1/4" per foot (2 cm per meter) pitch toward ice machine and should be secured to prevent dips and traps from forming.
4. Ducting must be provided if cabinet door does not mate directly to air intake gasket.
5. Cabinet interior must provide a minimum clear space of 23.50" (59.7 cm) high by 25.25" (64.1 cm) deep.
6. Grilles by others must meet minimum requirements for open air space shown above.
7. Utilities should be conveniently located as shown.

4 – Horizon Elite ice machine mounting accessories

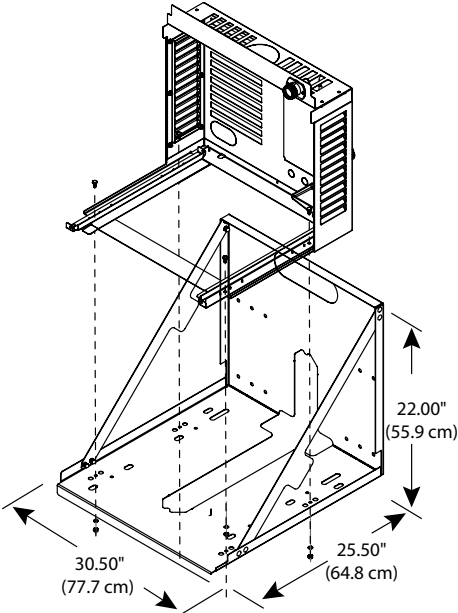
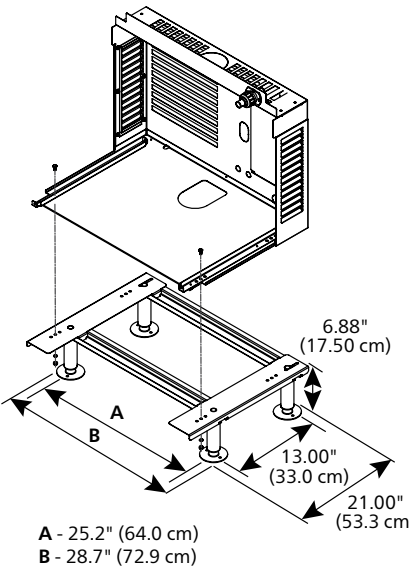
Optional wall mount bracket	Optional machine stand	Important specifier notes
 <p>30.50" (77.7 cm)</p> <p>22.00" (55.9 cm)</p> <p>25.50" (64.8 cm)</p>	 <p>6.88" (17.50 cm)</p> <p>13.00" (33.0 cm)</p> <p>21.00" (53.3 cm)</p> <p>A - 25.2" (64.0 cm)</p> <p>B - 28.7" (72.9 cm)</p>	<ol style="list-style-type: none"> For secure wall mounting, specify optional wall mount bracket. Wall and fasteners must support the weight of the ice machine, bracket, supply water and ice. Use of a backing board may be required with hollow wall construction. Machine stand mounting adds 6.88" (17.48 cm) to height of ice machine. No dips in tube routing allowed. Ice transport tube needs minimum 1/4" per foot (2 cm per meter) pitch toward ice machine and should be secured to prevent dips and traps from forming.

5 – Horizon Elite drain - specifier guidelines

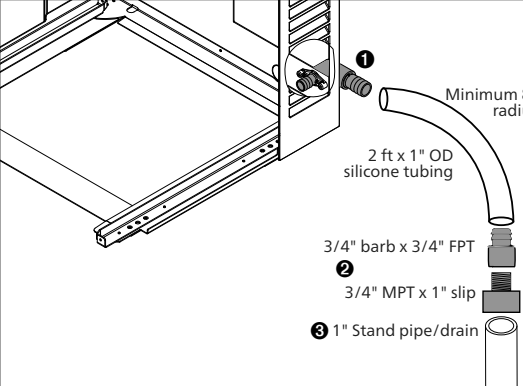
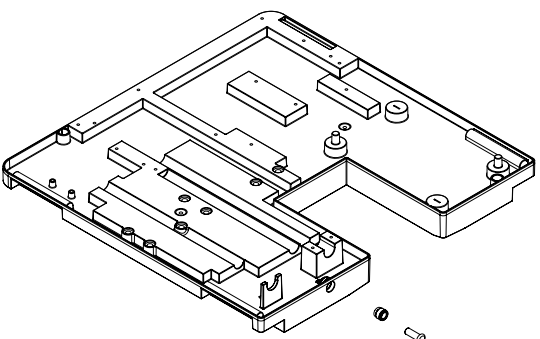
Flush drain plumbing – For regular machine drainage	Important specifier notes: Where code allows, follow recommendation below.
 <p>Minimum 8" radius</p> <p>2 ft x 1" OD silicone tubing</p> <p>① 3/4" barb x 3/4" FPT</p> <p>② 3/4" MPT x 1" slip</p> <p>③ 1" Stand pipe/drain</p>	<ol style="list-style-type: none"> Connect the silicone tubing to the ice machine 3/4" drain barb ①. Assemble the 3/4" barb x 3/4" FPT to the 3/4" MPT x 1" slip. Connect the other end of the silicone tubing to the 3/4" barb ②. Connect the 1" slip fitting to the 1" stand pipe/drain ③. <p>Note: Minimum 8" radius on silicone drain line. Drain line from the ice machine must have at least 1/4" per foot pitch (6.4 mm/0.3 m).</p> <p>Note: Stand pipe/drain provided by others. All other components provided with ice machine.</p>
Chassis drain plumbing – To assist with condensate in high humidity areas	Important specifier notes: Where code allows, follow recommendation below.
	<ol style="list-style-type: none"> Plug must be removed from John Guest fitting. Route 3/8" drain tubing through knockout in back of docking station and insert fully into John Guest fitting connection at the rear of the machine chassis. Route other end of 3/8" drain tubing to drain. Drain must slope 1/4" inch per foot (6 mm per 30.4 cm).

6 – Horizon Elite ice tube runs - specifier guidelines

Long tube runs for RIDE remote ice delivery equipment

beverage dispenser

support straps

minimum of 6.00" (15.24 cm) turn/corner radius

ice transport tube – 1 3/16" OD, 2 1/8" OD with insulation

maximum 2' (60.9 cm)

transport tube slope (toward ice machine) 1/4" 1' (2 cm per meter)

wall-mounted ice machine

Important specifier notes

- 75' (22.8 m) maximum ice transport tube run.
- Tubing routing bends must have a 6.00" (15.24 cm) radius or larger.
- Dips and traps are not allowed. If not supported from underneath, secure insulated ice transport tube at least every 2' (60.9 cm) to prevent drips and traps.
- Relative humidity levels above 80% in areas where the ice machine or ice transport tube is located may produce excessive condensation that will cause water damage.
- Contact factory for recommendations on running tubing through a decorative soffit or chase.

Ice production – Horizon Elite 1010 series, 60 Hz, air-cooled models

Inlet water temperature F (C)	Ambient air temperature F (C)					lb (kg) production in 24 hr
	60 (16)	70 (21)	80 (27)	90 (32)	100 (38)	
50 (10)	1160 (526)	1061 (481)	962 (436)	825 (374)	688 (312)	
60 (16)	1093 (496)	1001 (454)	909 (412)	795 (361)	681 (309)	
70 (21)	1026 (465)	941 (427)	857 (389)	765 (347)	674 (306)	
80 (27)	971 (440)	893 (405)	815 (370)	730 (331)	644 (292)	
90 (32)	917 (416)	841 (427)	773 (350)	694 (315)	614 (279)	

Ice production – All Horizon Elite 1410 series, air-cooled models

Inlet water temperature F (C)	Ambient air temperature F (C)					lb (kg) production in 24 hr
	60 (16)	70 (21)	80 (27)	90 (32)	100 (38)	
50 (10)	1593 (723)	1466 (665)	1339 (607)	1230 (558)	1121 (508)	
60 (16)	1518 (689)	1396 (633)	1275 (579)	1163 (528)	1052 (478)	
70 (21)	1442 (654)	1327 (602)	1211 (549)	1097 (498)	982 (446)	
80 (27)	1394 (632)	1272 (577)	1150 (522)	1050 (477)	950 (431)	
90 (32)	1345 (610)	1327 (602)	1089 (494)	1004 (456)	918 (417)	

Ice production – All Horizon Elite 1010 series, water-cooled models

Potable water temperature F (C)	Condenser water temperature F (C)					lb (kg) production in 24 hr
	60 (16)	70 (21)	80 (27)	90 (32)	100 (38)	
50 (10)	1096 (498)	1043 (473)	1001 (454)	947 (430)	892 (405)	
60 (16)	1006 (457)	970 (440)	938 (426)	888 (403)	839 (381)	
70 (21)	917 (416)	898 (408)	874 (396)	830 (377)	786 (357)	
80 (27)	874 (397)	826 (375)	826 (375)	787 (357)	749 (340)	
90 (32)	831 (377)	778 (353)	778 (353)	745 (338)	712 (323)	

Ice production – All Horizon Elite 1410 series, water-cooled models

Potable water temperature F (C)	Condenser water temperature F (C)					lb (kg) production in 24 hr
	60 (16)	70 (21)	80 (27)	90 (32)	100 (38)	
50 (10)	1436 (652)	1411 (641)	1385 (607)	1370 (622)	1354 (615)	
60 (16)	1417 (643)	1367 (633)	1318 (621)	1307 (593)	1296 (588)	
70 (21)	1397 (634)	1324 (602)	1251 (568)	1245 (565)	1238 (562)	
80 (27)	1318 (598)	1253 (577)	1189 (540)	1170 (531)	1151 (522)	
90 (32)	1238 (562)	1183 (602)	1127 (512)	1096 (497)	1064 (483)	



Agion is a registered trademark of Sciessent LLC.
 HORIZON ELITE, ICE•DEVICE, ICE MANAGER, MICRO CHEWBLET, SAFE/CLEAN PLUS, SANISPONGE, SYMPHONY PLUS and VISION are trademarks of Follett LLC.
 CHEWBLET, FOLLETT and RIDE are registered trademarks of Follett LLC, registered in the US.
 Follett reserves the right to change specifications at any time without obligation. Certifications may vary depending on country of origin.

Self-contained 1010, 1410 series ice machine