

Project: _____	AIA# _____
Item #: _____ Qty: _____	SIS# _____
Model #: _____	

Pass-Thru Coolers Two, Four, Six and Eight Door Self-Contained



PT60L-LL(LR/RL)



4004503

Conforms to NSF/ANSI STD 7 and UL STD 471
Certified to CSA STD C22.2 No. 120
PT108 meets NSF 7 requirements for closed container products
PT36 and PT60 meet NSF 7 requirements for open food storage
PT84 meets NSF 7 display refrigerator requirements for use in ambient temperatures not exceeding 86°F (30°C)

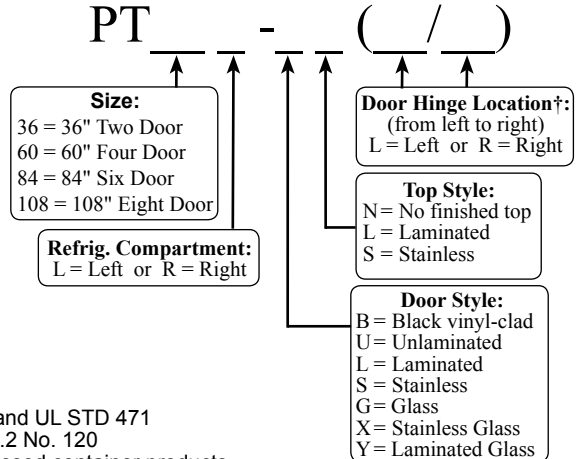

† Specify a hinge location for each door

Standard Features

- All stainless steel interior with radius corners is easy to keep clean
- Locking doors
- LED interior lighting
- Evaporator above compressor compartment to maximize storage capacity
- Any door opening may be converted to draft dispensing
- Available without a finished top for integrated installation below customer supplied counter top
- Easy to remove condenser filter can be regularly cleaned to maintain condenser coil efficiency
- Leg sockets recessed into base
- 180° swinging doors

Specifications

Electrical

- 120V, 1 phase, 60 Hz
- Full load amps - PT36 - 3.0, PT60, PT84, PT108 - 5.7
- Dedicated 15 amp circuit is required
- Includes a 6 foot NEMA 5-15P grounded cord and plug which exits the back of refrigeration compartment



Refrigeration

- R134a refrigerant
- Compressor - PT36 - 1/8 HP, BB60, BB84, BB108 - 1/4 HP
- Heat rejection - BB36 - 1228 BTU/Hr, BB60, BB84, BB108 - 2334 BTU/Hr

Operating Range

- 34°F (1°C) to 40°F (4°C)

Plumbing

- Automatic condensate evaporator. No drain connection required.

Shelving

- Two adjustable coated shelves and one bottom coated rack per door included

Materials

- Stainless steel parts include: interior, front of cabinet, hinges, hinge and lock brackets, and optional legs
- Black vinyl-clad steel parts include: standard sides, doors, and compressor covers
- Galvanized steel parts include: exterior sub-top and bottom
- Zinc plated CR steel parts include: leg sockets

Weight Bearing Capacity

- Counter tops and other accessories should not exceed 200 pounds per door

Capacities

	PT36	PT60	PT84	PT108
• 12 oz. bottles, cases	8.8	19.1	29.9	40.6
• 750ml wine bottles	79	177	271	365
• 1/2 barrel kegs	1	2	4	5
• 1/6 barrel kegs	4	8	14	18

Glastender, Inc. • 5400 N Michigan Rd • Saginaw, MI • 48604-9780
989.752.4275 • 800.748.0423 • Fax 989.752.4444
www.glastender.com

Approval/Notes:

Specifications subject to change without notice. For current specifications please visit our website.

Self-Contained Pass-Thru Coolers

Dimensional Information

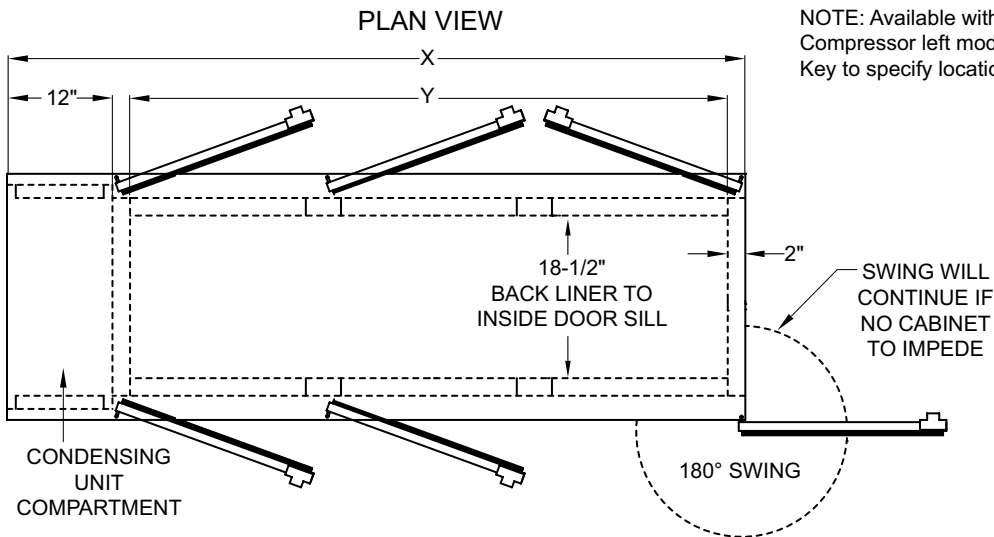

Model	X	Y	DOORS
PT36	36"	20"	1
PT60	60"	44"	2
PT84	84"	68"	3
PT108	108"	92"	4

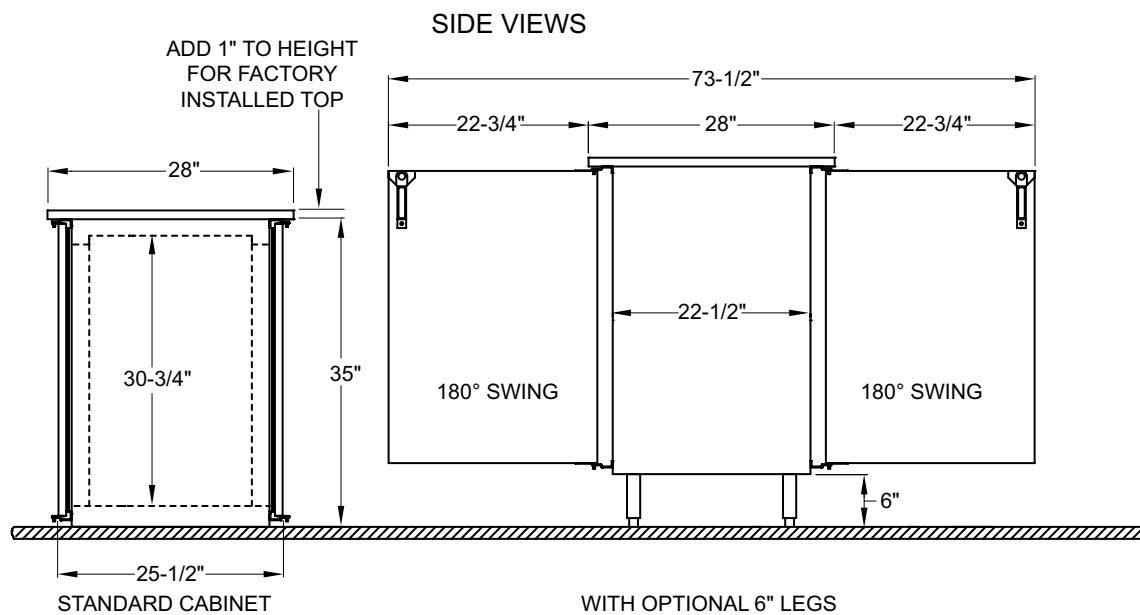
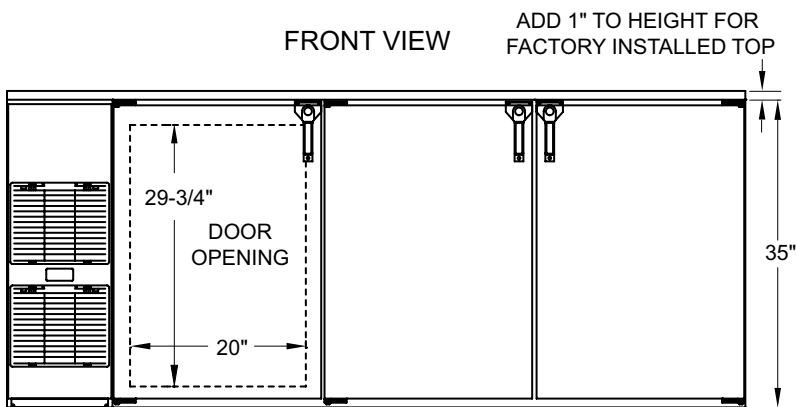

5400 N Michigan Rd • Saginaw, MI • 48604-9780
 989.752.4275 • 800.748.0423 • Fax 989.752.4444
 www.glastender.com