

Project: _____	AIA# _____
Item #: _____ Qty: _____	SIS# _____
Model #: _____	

Liquor Displays

See reverse side for model number key



LDA-24



Intertek

4004503

Conforms to ANSI/NSF STD 2

Standard Features

- Easily useable height for storage
- All stainless steel construction and stainless steel bullet feet
- Includes radius interior corners for easy cleaning
- Four (4) levels of liquor bottle storage for 24" deep models and five (5) levels for 29" deep models
- Bottle retaining rails with clear lift-off liquor identification cover
- Open step-and-rail design for easy cleaning and better view of bottles
- Locking covers are available for each individual row, see Locking Speed Rail Covers on page 3.32
- Matches speed rail design for continuity
- Specially designed side profiles to align with four different equipment mounting situations
- Standard models available in 6" incremental lengths from 12" to 42" (Custom sizes also available)
- Rear step on each model is extra wide for specialty liquor bottles

To view underbar installation instructions, please visit: http://www.glastender.com/PDF/F-750-165_Underbar_Installation_Instructions.pdf
 To view cleaning and care instructions, please visit: http://www.glastender.com/PDF/F-423-011_ss_clean_care.pdf

Specifications	Product Information
-----------------------	----------------------------

Legs

- 1-5/8" diameter, 16 gauge stainless steel
- Stainless steel bullet feet

Materials

- 20 gauge stainless steel parts include: all components unless otherwise noted
- 18 gauge stainless steel parts include: leg pads
- 14 gauge stainless steel parts include: sides
- ABS plastic step and rail covers

Liquor Displays provide tiered liquor bottle storage at a height convenient for bartender use. They maintain the same easy to clean, open step and rail design as a speed rail. Each step and rail has ABS sound deadening covers and each rail includes a clear lift-off liquor identification cover. The 24" deep models provide four levels of storage front to back and the 29" deep models provide five.

Liquor displays cannot have a speed rail mounted to them. Since speed rails are so common on underbar, liquor displays have been designed to align with underbar that has a speed rail. The four different liquor display styles are based on the four different equipment mounting situations.

Glastender, Inc. • 5400 North Michigan Road • Saginaw, MI • 48604-9780 989.752.4275 • 800.748.0423 • Fax 989.752.4444 www.glastender.com	Approval/Notes:
Specifications subject to change without notice. For current specifications please visit our website.	

Liquor Displays

Dimensional Information

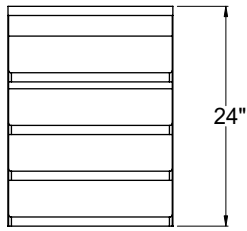

PLAN VIEW
(both models)

24" Deep Models

Model Number	Model Number	X
LDA-12S	LDB-12	12"
LDA-18S	LDB-18	18"
LDA-24S	LDB-24	24"
LDA-30S	LDB-30	30"
LDA-36S	LDB-36	36"
LDA-42S	LDB-42	42"

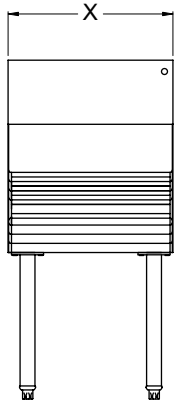

FRONT
ELEVATION

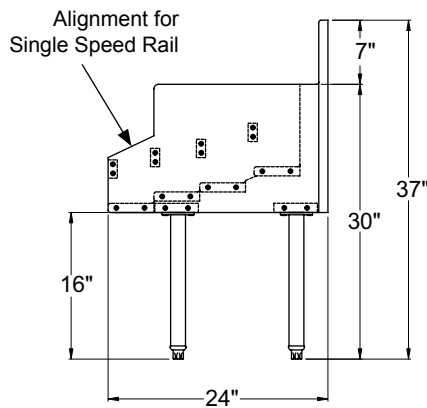

LDA-__S

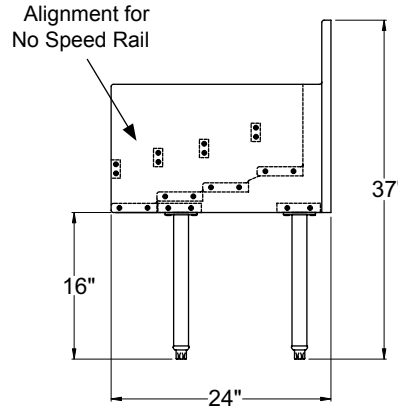

LDB-__

SIDE ELEVATIONS

* Denotes length in inches

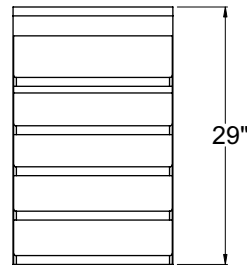

PLAN VIEW
(both models)

29" Deep Models

Model Number	Model Number	X
LDA-12D	LDB-12S	12"
LDA-18D	LDB-18S	18"
LDA-24D	LDB-24S	24"
LDA-30D	LDB-30S	30"
LDA-36D	LDB-36S	36"
LDA-42D	LDB-42S	42"

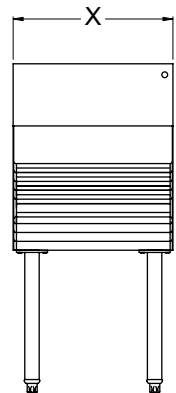

FRONT
ELEVATION

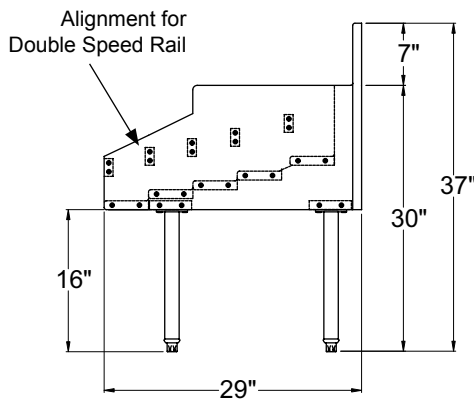

LDA-__D

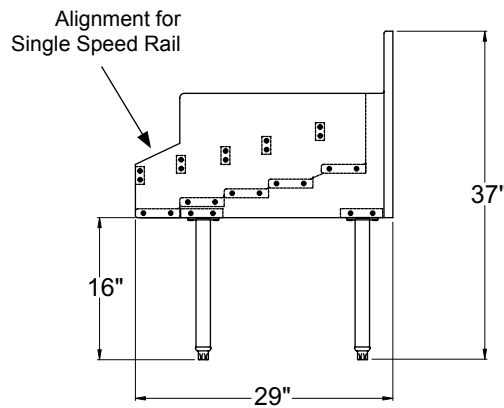

LDB-__S

SIDE ELEVATIONS

* Denotes length in inches