

Project: _____	AIA# _____
Item #: _____ Qty: _____	SIS# _____
Model #: _____	

Drainboard Blender Stations

DBSA-12, DBSA-14, DBSA-18, DBSA-24,
 DBSB-12, DBSB-14, DBSB-18



DBSB-18
 (Blender not included)



Intertek
 4004503
 Conforms to ANSI/NSF STD 2

Standard Features

- All stainless steel construction
- One-piece, seamless top and backsplash featuring 1/4" radius corners for easy cleaning
- CFC free foamed-in-place blender shelf for sound deadening
- Adjustable stainless steel bullet feet
- Drainboard work surface consists of drain pan with separate removable perforated insert
- Blender shelf features radius interior corners for easy cleaning
- Power cord access hole with grommet located on front skirt, behind the blender
- Junction box for duplex GFI outlet mounted underneath blender shelf (outlet not included)

NOTE: Blender stations cannot have a speed rail mounted to them. Since speed rails are so common on underbar, blender stations come in 24" and 29" depths to align with underbar that has a speed rail.

To view underbar installation instructions, please visit: http://www.glastender.com/PDF/F-750-165_Underbar_Installation_Instructions.pdf
 To view cleaning and care instructions, please visit: http://www.glastender.com/PDF/F-423-011_ss_clean_care.pdf

Specifications

Drain

- 1-1/2" I.P.S. Threaded drain will fit Dearborn part #8033 slipnut and part #W-573P washer.

Legs

- 1-5/8" diameter, 16 gauge stainless steel
- Stainless steel bullet feet

Materials

- 20 gauge stainless steel



Power cord access hole in front skirt, behind blender

<p>Glastender, Inc. • 5400 N Michigan Rd • Saginaw, MI • 48604-9780 989.752.4275 • 800.748.0423 • Fax 989.752.4444 www.glastender.com</p>	<p>Approval/Notes:</p>
Specifications subject to change without notice. For current specifications please visit our website.	

Drainboard Blender Stations

Dimensional Information

24" Deep Models

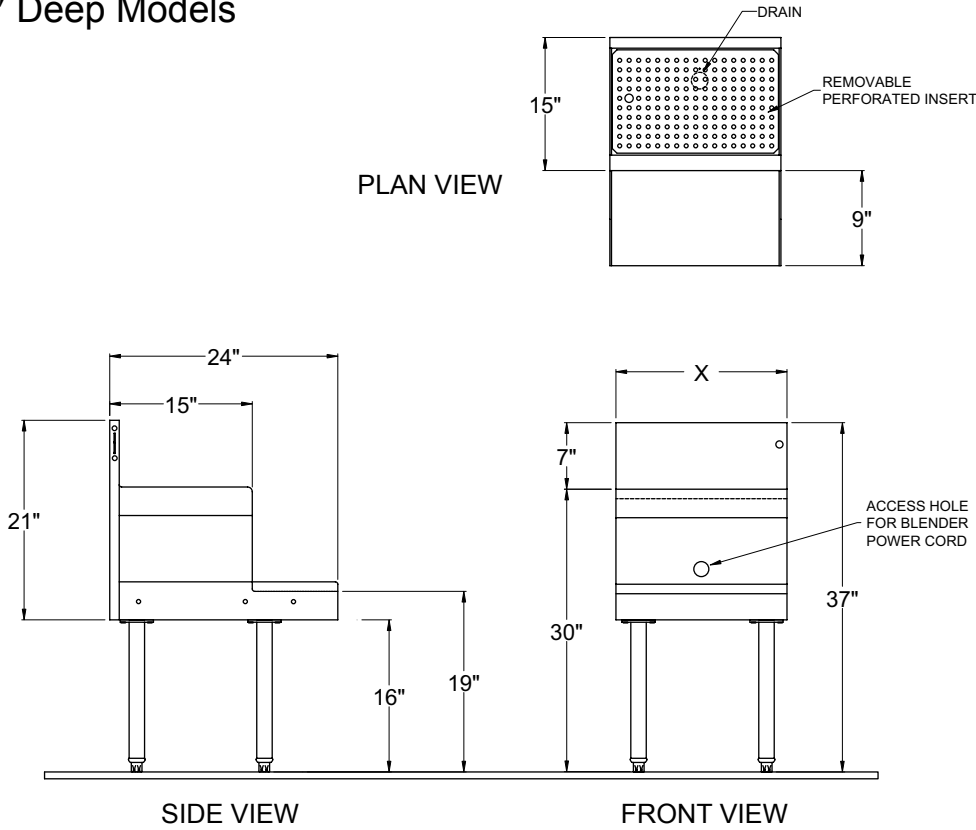

Model #	X
DBSA-12	12"
DBSA-14	14"
DBSA-18	18"
DBSA-24	24"

29" Deep Models

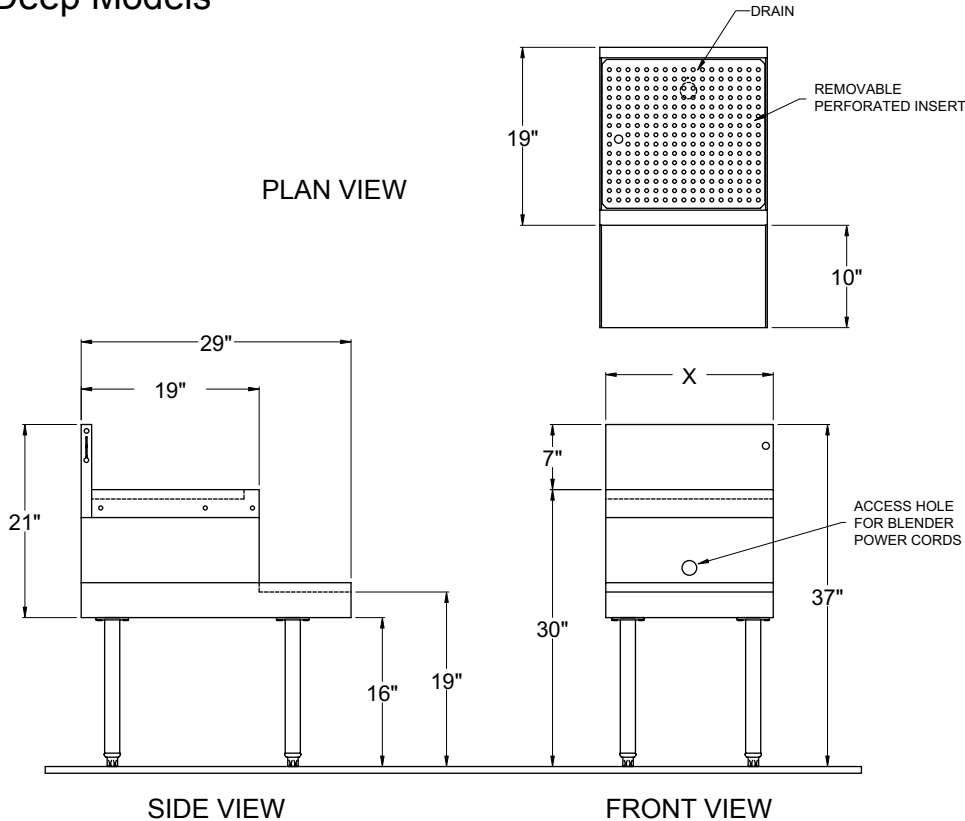

Model #	X
DBSB-12	12"
DBSB-14	14"
DBSB-18	18"



5400 N Michigan Rd • Saginaw, MI • 48604-9780
 989.752.4275 • 800.748.0423 • Fax 989.752.4444
www.glastender.com