

Project: _____	AIA# _____
Item #: _____ Qty: _____	SIS# _____
Model #: _____	

One, Two And Three Door Dry Storage Cabinets



DS24-N1-BSN(R)

DS ___ -N ___ - ___ - ___ N(___)

Size:
24 = 24" One Door
48 = 48" Two Doors
72 = 72" Three Doors

Door Hinge Location:
(from left to right)
L = Left or R = Right

Base Height:
1 = 1"
6 = 6" Legs only

Top Style:
N = No finished top
L = Laminated
S = Stainless

Door Style:
B = Black vinyl-clad
U = Unlaminated
L = Laminated
S = Stainless

Standard Features

- Galvanized steel interior construction
- Foamed-in-place insulation for extra sturdiness
- Galvanized steel sub-top on DS48 and DS72 models
- Black vinyl-clad steel exterior front and sides
- Stainless steel die cast handle with lock
- Leg sockets recessed into base
- 180° swinging doors



Intertek

4004503

Conforms to NSF/ANSI STD 2

To view underbar installation instructions, please visit: http://www.glastender.com/PDF/F-750-165_Underbar_Installation_Instructions.pdf
To view cleaning and care instructions, please visit: http://www.glastender.com/PDF/F-423-011_ss_clean_care.pdf

Specifications

Shelving

- Two adjustable shelves per door included

Legs

- 1-5/8" diameter
- Stainless steel bullet feet

Materials

- 22 gauge black vinyl-clad parts include: sides and standard doors
- 16 gauge stainless steel parts include: legs
- 16 gauge galvanized steel parts include: base
- 16 gauge zinc plated CR steel parts include: leg sockets
- 12 gauge stainless steel parts include: hinges, hinge brackets, and lock brackets

Glastender, Inc. • 5400 North Michigan Road • Saginaw, MI • 48604-9780
989.752.4275 • 800.748.0423 • Fax 989.752.4444
www.glastender.com

Approval/Notes:

Specifications subject to change without notice. For current specifications please visit our website.

Dry Storage Cabinets

Dimensional Information

PLAN VIEW

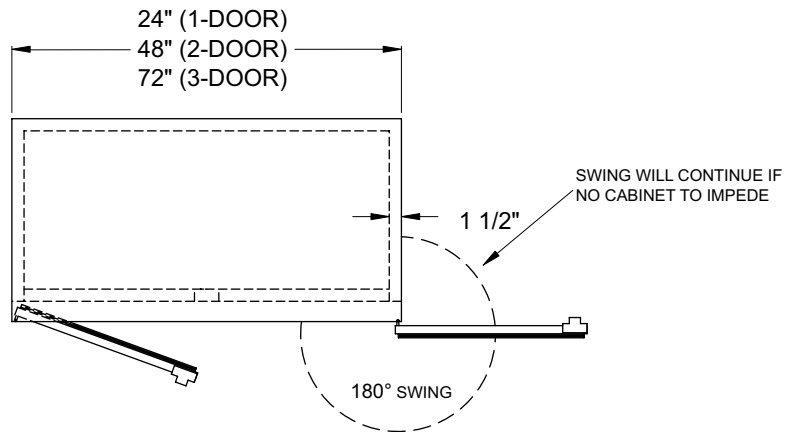

FRONT VIEW

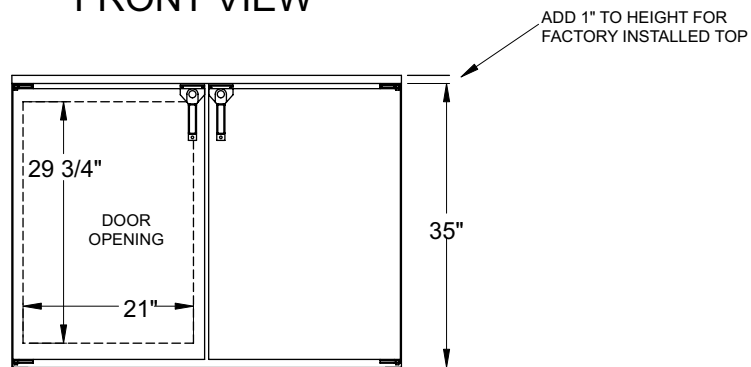

SIDE VIEWS

