

Project: _____	AIA# _____
Item #: _____ Qty: _____	SIS# _____
Model #: _____	

# Dry Waste Rail

DWR-12

## Standard Features

- All stainless steel construction
- Matches speed rail profile for continuity of design
- Bolts to the front skirt of non-cabinet base underbar equipment or clips to the rail of an underbar speedrail
- Stainless steel chute is removable for cleaning

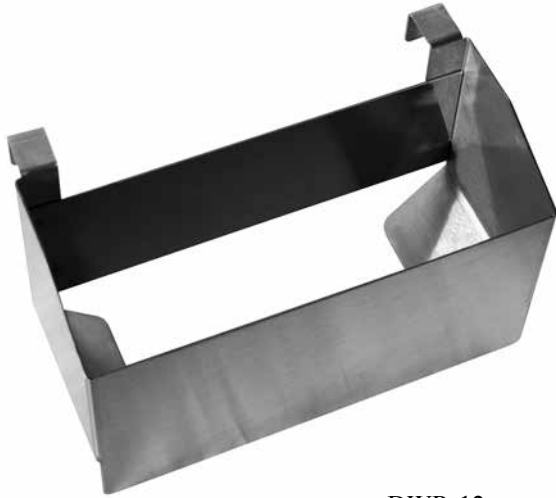

DWR-12  
(clip on style shown)



**Intertek**  
 4004503  
 Conforms to ANSI/NSF STD 2

To view cleaning and care instructions, please visit: [http://www.glastender.com/PDF/F-423-011\\_ss\\_clean\\_care.pdf](http://www.glastender.com/PDF/F-423-011_ss_clean_care.pdf)

## Specifications

*Materials*

- 16 gauge stainless steel

The removable stainless steel Dry Waste Rail is a 12" wide by 5" deep trash chute that matches the profile of a speed rail. A 16" high or shorter trash receptacle is placed under the dry waste rail and the chute directs the refuse into the receptacle. Dry waste rails cannot be used on cabinet base underbar equipment. A stainless steel dry waste receptacle, model DWC, is available as an accessory.

<b>Glastender, Inc.</b> • 5400 North Michigan Road • Saginaw, MI • 48604-9780 989.752.4275 • 800.748.0423 • Fax 989.752.4444 www.glastender.com	Approval/Notes:
Specifications subject to change without notice. For current specifications please visit our website.	

# Dry Waste Rail

## Dimensional Information

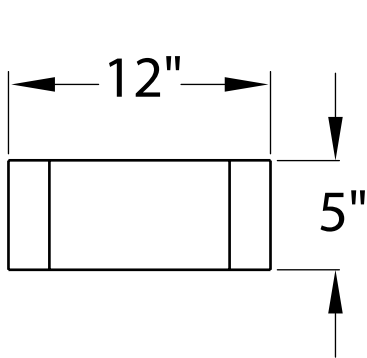
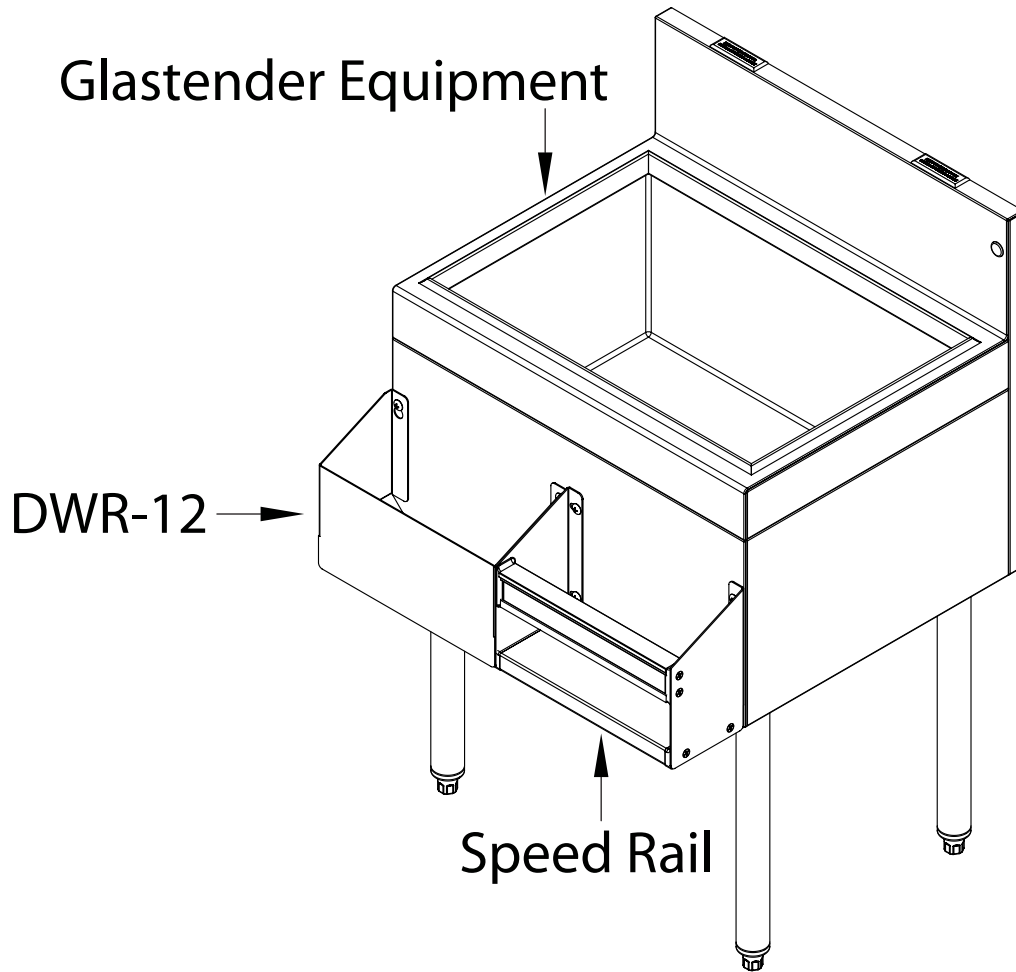

PLAN VIEW

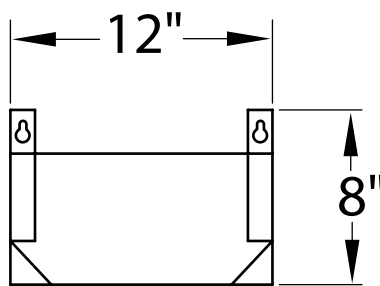

FRONT ELEVATION

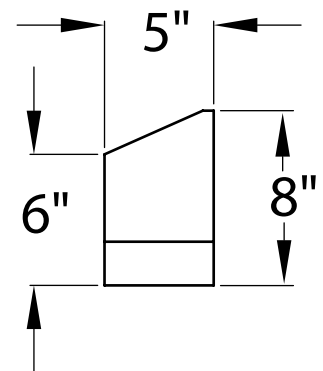

SIDE ELEVATION

(key hole style illustrated)