

Project: _____	AIA# _____
Item #: _____ Qty: _____	SIS# _____
Model #: _____	

Extended GT-18+2's

Rotary Rack, Fill & Dump, Side-to-Side Pass Thru Glasswasher
 (model numbers on reverse side)



GT-18+2-78L with 01000708 Glass Rack Holder and four extra 01000532 Glass Racks

Standard Features

- Built-in drain tables on each side to provide glass landing area and increase throughput
- Removable top for easy cleaning access (GT-18, GT-18+1, GT-18+1L, GT-18+1R, GT-18+2, and GT-18+2-IC tops are interchangeable)
- Drive Wheel and Glass Rack lift out for cleaning
- Two 16" diameter polypropylene racks included
- Set of two end curtains included
- Removable side panels for easy service access
- Spray box unlatches for easy cleaning and visual inspection - 15 spray nozzles have been engineered for maximum soil removal
- Digital temperature gauge built into switch panel
- Intelligent microprocessor control delays cycle start, up to two minutes, when incoming water is below 120°F (49°C)
- Automatic peristaltic metering pumps accurately dispense detergent, sanitizer and rinse aid
- Prime Switch for quick chemical priming
- 1/6 HP pump recirculates wash water and rinse water
- Fractional HP drive motor powers the belt-driven rotary rack and includes built-in slip clutch



Intertek



Intertek

4004503

Conforms to NSF/ANSI STD 3 and UL STD 921
 Certified to CSA STD C22.2 No. 168

Specifications

General Plumbing

- Plumb with 1/2" water supply. Adapt to 3/8" FMPT.
- Minimum water pressure is 25 PSI
- Maximum water pressure is 100 PSI. Install water pressure regulator if line pressure is over 100 PSI. Water valve on unit has built-in strainer and flow control to provide consistent volume between 25 and 100 PSI
- Install separate water shut-off valve
- Unit has built-in air gap - vacuum breaker is not required
- Maximum temperature is 150°F (66°C)
- Minimum temperature is 120°F (49°C)
- Consumption is 2-1/2 gallons per cycle

Drain

- 1-1/2" tailpiece
- Use open type floor drain for maximum drainage

Electrical

- 120V, single phase, 60Hz, 6-foot NEMA 5-15P grounded cord included
- Dedicated 15 amp circuit recommended
- Power requirements - 3.5 amps



Detergent

- Extra heavy duty, non-foaming, commercial liquid dishwashing detergent is required - .30% concentration
- Consult local chemical supplier to match detergent with local water conditions

Sanitizer

- Liquid chlorine bleach (sodium hypochlorite - 5.25% solution) adjusted to 50 ppm

Rinse Aid

- Liquid Rinse Aid adjusted for proper sheeting

Capacity

- 2 minute cycle, 70 second wash and 22 second rinse exposure
- 720 - 2-1/2" diameter or 600 - 2-3/4" diameter glasses per hour (maximum glass height 10" - including pitchers and wine carafes)

Materials

- 20 gauge stainless steel parts include: cabinet
- 18 gauge stainless steel parts include: floor and tanks
- 16 gauge stainless steel parts include: leg mounting brackets and legs
- 11 gauge stainless steel parts include: drive wheel

Installation Considerations

- 1" clearance required to remove top
- Front side service is essential
- Detergent, Sanitizer, and Rinse Aid containers are stored externally - six-foot lengths of tubing are provided. Storage for three one-gallon containers is required within five feet.

Glastender, Inc. • 5400 North Michigan Road • Saginaw, MI • 48604-9780
 989.752.4275 • 800.748.0423 • Fax 989.752.4444
www.glastender.com

Approval/Notes:

Specifications subject to change without notice. For current specifications please visit our website.

Extended GT-18+2 Glasswashers

Dimensional Information

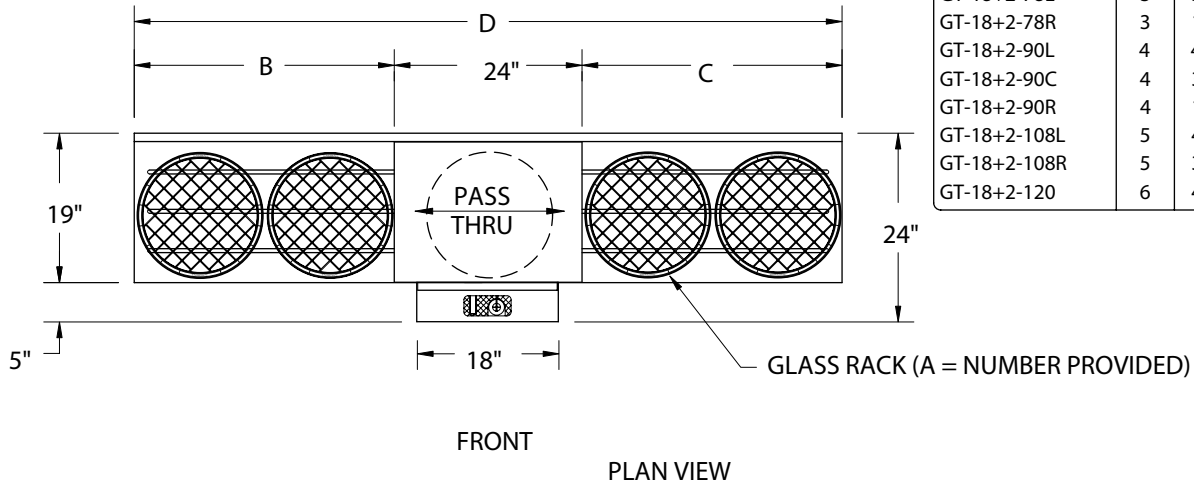

MODEL #	A	B	C	D
GT-18+2-78L	3	36"	18"	78"
GT-18+2-78R	3	18"	36"	78"
GT-18+2-90L	4	48"	18"	90"
GT-18+2-90C	4	33"	33"	90"
GT-18+2-90R	4	18"	48"	90"
GT-18+2-108L	5	48"	36"	108"
GT-18+2-108R	5	36"	48"	108"
GT-18+2-120	6	48"	48"	120"

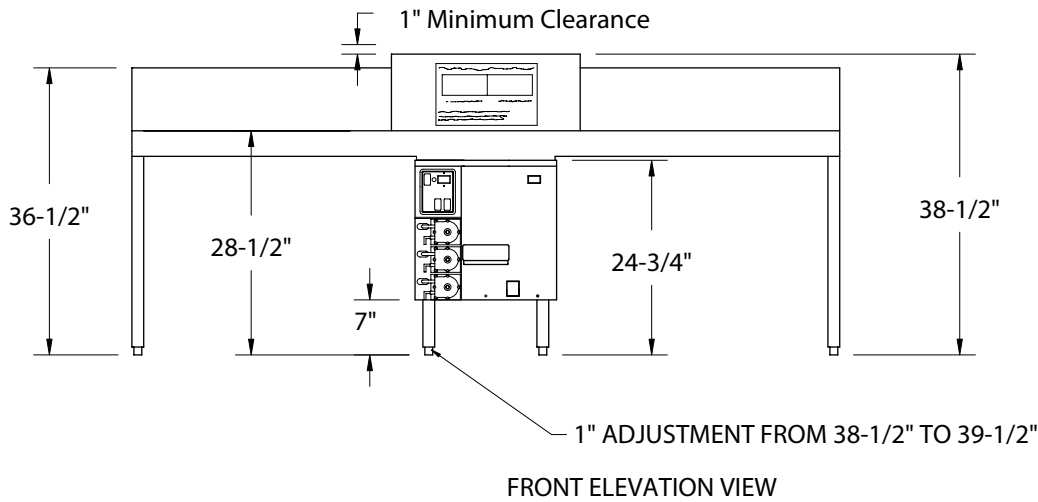

Mechanicals

- Note: 1. In all cases, consult local plumbing, electrical and health codes for regulations which may not be consistent with the information on the front of this specification sheet
2. The utility connections are made from the floor at the bottom of the unit approximately 7" to 8" high.
3. The Glastender policy of constant quality improvement means specifications are subject to change without notice.

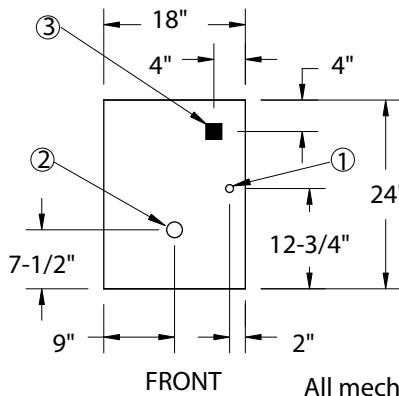

- ① = HOT WATER
- ② = DRAIN
- ③ = ELECTRICAL

All mechanicals measured from GT-18 base



5400 North Michigan Road • Saginaw, MI • 48604-9780
 989.752.4275 • 800.748.0423 • Fax 989.752.4444
www.glastender.com