

Project: _____	AIA# _____
Item #: _____ Qty: _____	SIS# _____
Model #: _____	



PT48L-SN(LL/RR)



4004503
Conforms to NSF/ANSI STD 7 and UL STD 471
Certified to CSA STD C22.2 No. 120
Meets NSF 7 requirements for open food storage

Pass-Thru Coolers Four, Six and Eight Door Remote

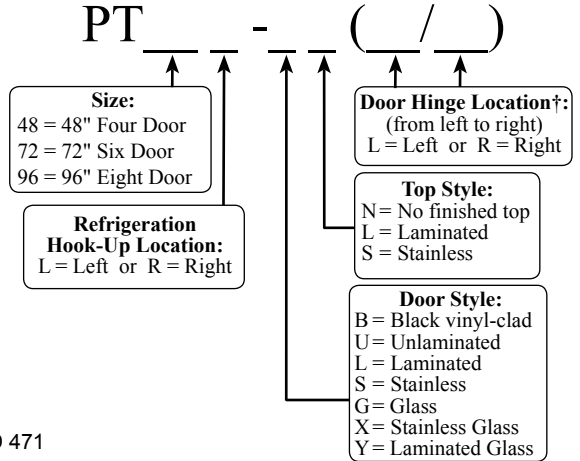

† Specify a hinge location for each door

Standard Features

- Remote unit
- All stainless steel interior with radius corners is easy to keep clean
- Locking door(s)
- LED interior lighting
- Available without a finished top for integrated installation below customer supplied counter top
- 180° swinging doors
- Leg sockets recessed into base

Specifications

Electrical

- 120V, 1 phase, 60 Hz
- Dedicated 15 amp circuit is required
- 14 gauge wire connection is made inside the cooler next to evaporator housing - interior access is through one of the 3/4" side knock-out holes (electrician's choice)

Refrigeration

- R134a* or R404a* expansion valve & temperature control included. Specify type required when ordering.
- Refrigeration system capacity requirements*:
PT48 - 1,970 BTU/hr
PT72 - 2,500 BTU/hr
PT96 - 3,030 BTU/hr
- * BTU/hr design loads are figured assuming 85° F ambient, all glass doors, maximum internal loading, and average compressor cycling. No solar heat gain has been accounted for.
- All refrigeration hookups are made at the installation site

Plumbing

- A ten foot length of 1/2" ID by 5/8" OD plastic tubing is provided to drain condensate. The tubing should exit through one of the 3/4" side knock-out holes (installer's choice). The maximum drainage is one ounce per hour - consult local codes for compliance - a floor drain may be required

Shelving

- Two adjustable coated shelves and one bottom coated rack per door included

Materials

- Stainless steel parts include: interior, front of cabinet, hinges, hinge and lock brackets, and optional legs
- Black vinyl-clad steel parts include: standard sides and doors
- Galvanized steel parts include: exterior sub-top and bottom
- Zinc plated CR steel parts include: leg sockets

Weight Bearing Capacity

- Counter tops and other accessories should not exceed 200 pounds per door

Capacities	PT48	PT72	PT96
• 12 oz. bottles, cases	17.6	28.3	39.1
• 750ml wine bottles*	156	253	350

Glastender, Inc. • 5400 N Michigan Rd • Saginaw, MI • 48604-9780
989.752.4275 • 800.748.0423 • Fax 989.752.4444
www.glastender.com

Approval/Notes:

Specifications subject to change without notice. For current specifications please visit our website.

Remote Pass-Thru Coolers

Dimensional Information

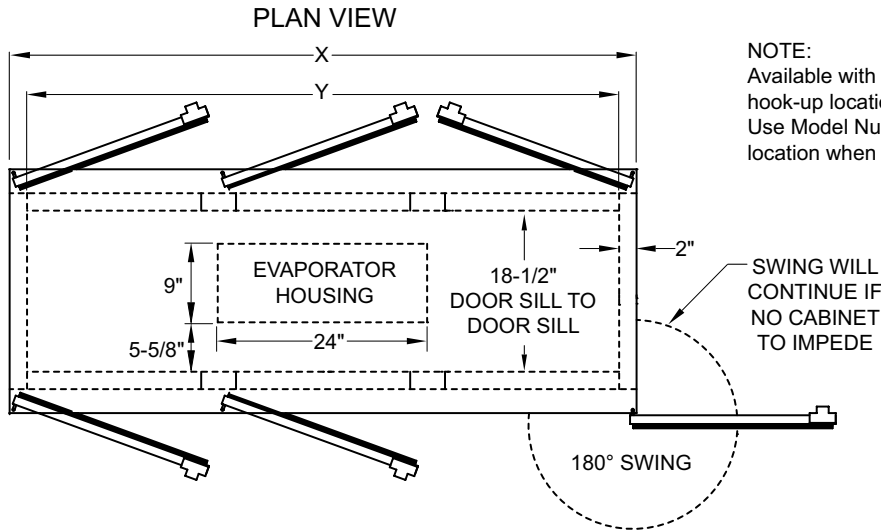

Model	X	Y	DOORS
PT48	48"	44"	4
PT72	72"	68"	6
PT96	96"	92"	8

