

Project: _____	AIA# _____
Item #: _____ Qty: _____	SIS# _____
Model #: _____	

Shallow-Well Slide Top Coolers



ST24-SF



Intertek



Intertek

4004503

Conforms to NSF/ANSI STD 7 and UL STD 471

Certified to CSA STD C22.2 No. 120

Meets NSF 7 requirements for closed container products

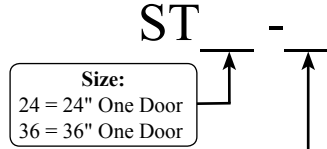

Finish Options:	
BG = Black vinyl-clad steel	} Galvanized Steel Interior with Stainless Steel Floor
SFG = Stainless steel front and side	
SG = All stainless steel	
B = Black vinyl-clad steel	} Stainless Steel Interior
SF = Stainless steel front and sides	
S = All stainless steel	

Standard Features

- Meets 2008 energy efficiency standards
- Self-contained refrigeration
- Automatic defrost cycle
- Radius interior corners for easy cleaning
- Perfect exterior dimensions: 24" front to back and 24" or 36" left to right
- CFC free foamed-in-place insulation
- Two interior options: galvanized steel walls and stainless steel floor or all stainless steel
- Three exterior options: black vinyl-clad steel, stainless steel front & sides, or all stainless steel
- Six foot grounded cord & plug included (exits left rear)
- Optional 3-3/4" casters or 6" legs are available
- Automatic condensate evaporator - no drain connection required
- One-piece integral top design
- Door lock

Specifications

Electrical

- 120V, 1 phase, 60 Hz, 3.7 full load amps
- Dedicated 15 amp circuit is recommended
- Includes a 6-foot NEMA 5-15P grounded cord and plug which exits the left rear of the refrigeration compartment

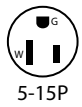

Refrigeration

- 1/8 HP, R134a refrigerant
- Operating range: 30°F (-1°C) to 40°F (4°C)
- Fin & tube evaporator with forced air circulation
- 2,375 BTU/hr heat rejection

Plumbing

- Automatic condensate evaporator. No drain connection required

Partitions

- ST24 includes one vertical wire partition
- ST36 includes two vertical wire partitions

Capacity

- 24" model = 116 long neck bottles (4.83 cases)
- 36" model = 174 long neck bottles (7.25 cases)

Legs

- Optional 6" legs, specify accessory #STLS-4
- 1-5/8" diameter
- Stainless steel bullet feet

Materials

- 20 gauge stainless steel parts include: top, door, interior floor, back*, front*, and sides* (*if all stainless finish is specified)
- 20 gauge black vinyl-clad steel parts include: front and sides (if black vinyl-clad steel body finish is specified)
- 22 gauge stainless steel parts include: interior walls (if stainless interior is specified)
- 22 gauge galvanized steel parts include: interior walls (if galvanized steel interior is specified) and back
- 16 gauge stainless steel parts include: legs* (* if specified)
- 16 gauge galvanized steel parts include: base

<p>Glastender, Inc. • 5400 N Michigan Rd • Saginaw, MI • 48604-9780 989.752.4275 • 800.748.0423 • Fax 989.752.4444 www.glastender.com</p>	<p>Approval/Notes:</p>
<p>Specifications subject to change without notice. For current specifications please visit our website.</p>	

Shallow-Well Slide Top Coolers

Dimensional Information

Model	A	B	No. of Doors
ST24	24"	20"	1
ST36	36"	32"	1

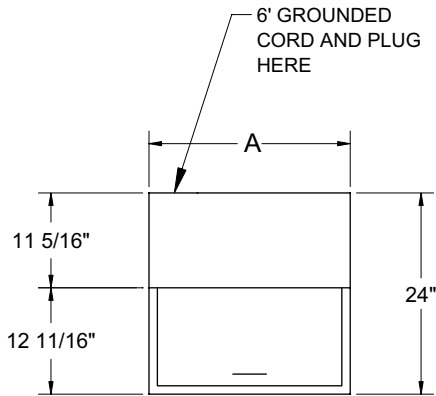

PLAN VIEW

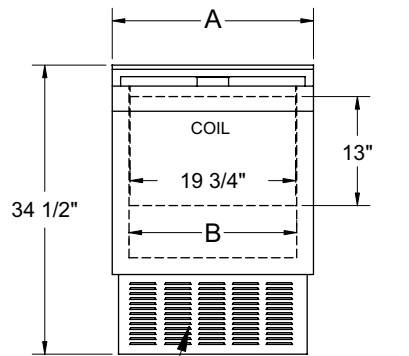

FRONT ELEVATION

REFRIGERATION COMPARTMENT

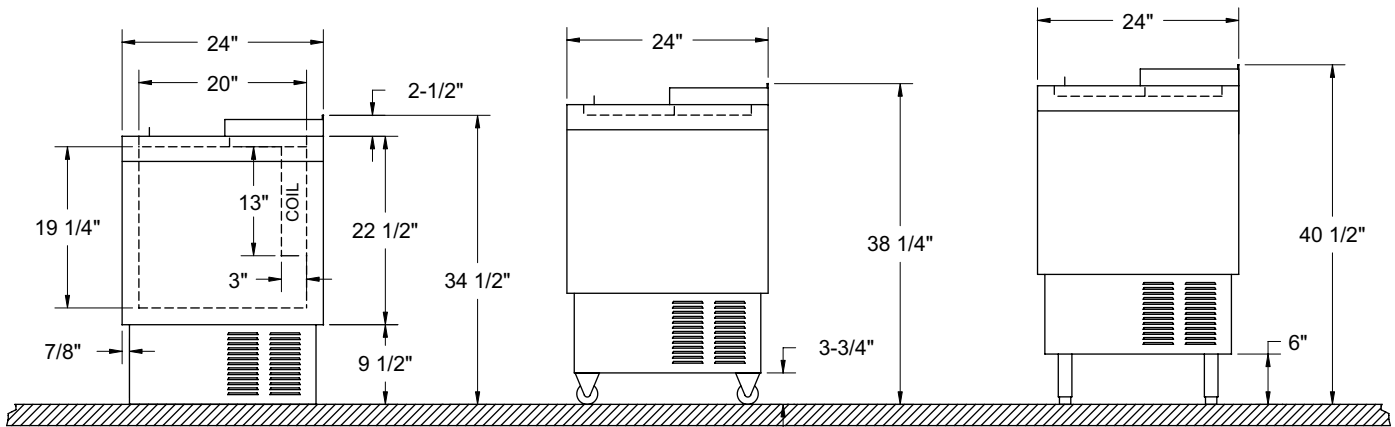

Standard Base

Optional Casters

Optional 6" Legs

TYPICAL END VIEWS