



GAS CONVECTION STEAMER

HIGH EFFICIENCY/PERFORMANCE

7, 10 AND 16 PAN CAPACITY

Model	Compartments	Capacity
GSX-7HE	2	1-7 Pans (2-1/2")
GSX-10HE	2	1-10 Pans (2-1/2")
GSX-16HE	2	1-16 Pans (2-1/2")

Standard Features

- Water Treatment System
- Stainless steel construction -including cabinet and generators
- Electronic ignition
- Coved interior corners
- Automatic generator blow down
- Delime mode power setting
- Deliming port is located at the front of the generator for easy access to allow cleaning of the tank
- Split water connections for simple hook up for a treated water system.
- Left side access panel
- Thermostatically controlled drain
- Single drain connection
- Safety relief valve
- Separate controls and generator for each compartment



GSX-10HE

Job _____
Item# _____

CONSTRUCTION SPECIFICATIONS

Southbend convection steamer with individual gas steam generators for each cavity. The GSX-7HE has two compartments: (1) 3-pan and (1) 4-pan; GSX-10HE has two compartments: (2) 5-pans; GCX-16HE has two compartments: (2) 8-pans. The steamer shall be constructed of satin finish stainless steel type #304. The cooking chamber is a one piece all welded, #316 stainless steel with coved corners. The heavy duty door shall have an inner liner of stainless steel with a full perimeter gasket seal, an outer liner of one piece all welded stainless steel, and a positive lock and seal mechanism with spring release. Each compartment shall be provided with removable stainless steel pan supports. A stainless steel drip trough shall be integrally connected to drain to collect condensate when the doors are opened.

The control housing shall be constructed of stainless steel with a full access removable panel. Each compartment shall have individual controls which include an illuminated three way power switch (ON/OFF/Delime), a pilot ready light, a pilot cooking light, an ignition light, a 60-minute electric timer which sounds an audible signal at the end of the cooking cycle, solid state generator controls and electronic ignition for each generator. Steam flow to the cooking chamber shall be cut off when the door is opened and reactivated when the door is closed. Steamers are mounted on a 24" stainless steel cabinet base (GCX-16HE is mounted on a 36" cabinet base) with exterior hinged door and 6" stainless steel adjustable legs -bullet feet on front and flanged on rear. The cabinet houses the generator(s), automatic blow down and drain box.

AGA/CGA Certified and NSF Approved.

WATER QUALITY STATEMENT

Water quality is the major factor affecting the performance of your appliance. If you are unsure of water quality, consult a local water treatment specialist and have the water analyzed. Your water supply must be within these general guidelines:

- Total dissolved solids - less than 60 PPM
- Total alkalinity - less than 20 PPM
- Silica - less than 13 PPM
- Chlorine -less than 1.5 PPM
- pH Factor -7.0-8.5

Water which fails to meet these standards should be treated by installation of water conditioner.

SOUTHBEND WATER TREATMENT SYSTEM MUST BE USED, FOR THIS APPLIANCE TO BE COVERED UNDER WARRANTY



Models: GSX-7HE GSX-10HE GSX-16HE

* Use on non-combustible floors only.

MODEL	SHIPPING WT	GAS SUPPLY PRESSURE			
		BTU/HR.	kW/HR.	NATURAL	PROPANE
GSX-10HE	700lbs (318kg)	190,000	56	6"-14" (152-356mm)	12"-14" (305-356mm)

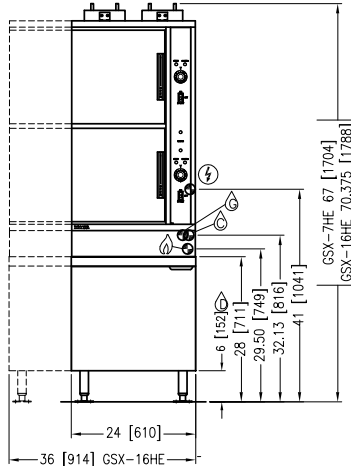

FLANGED FOOT DETAIL
2 EQUALLY SPACED
Ø7/16" [11mm] HOLES
ON 2-1/2" [63mm] B.C.

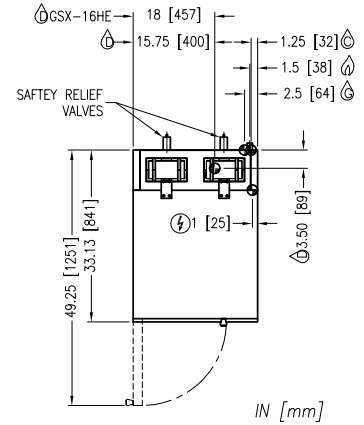

MODEL	SHIPPING WT	GAS SUPPLY PRESSURE			
		BTU/HR.	kW/HR.	NATURAL	PROPANE
GSX-7HE	650lbs (295kg)	140,000	41	6"-14" (152-356mm)	12"-14" (305-356mm)
GSX-16HE	900lbs (408kg)	190,000	56	6"-14" (152-356mm)	12"-14" (305-356mm)

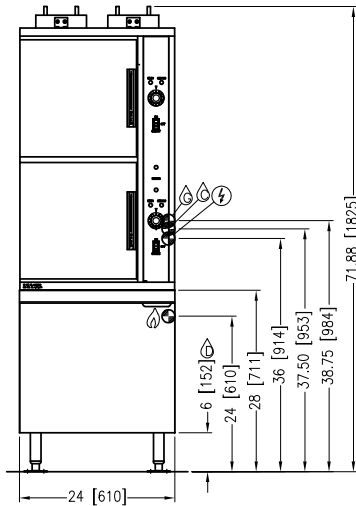

FLANGED FOOT DETAIL
2 EQUALLY SPACED
Ø7/16" [11mm] HOLES
ON 2-1/2" [63mm] B.C.

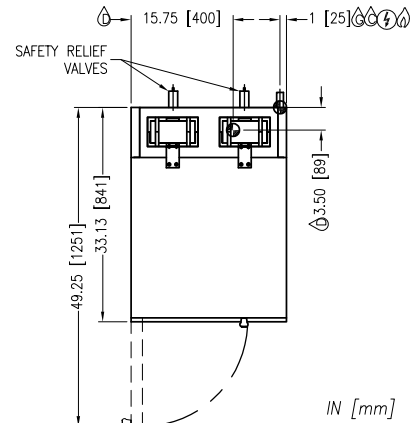

UTILITY CONNECTIONS

Gas fired, stainless steel steam generators operating at 0 psi (0kPa) and rated at:

TOTAL: GSX-7HE 140,000 BTU; GSX-10HE 190,000 BTU; GSX-16HE 190,000 BTU

Required minimum inlet pressure:

- Natural Gas 6" W.C.
- Propane Gas 12" W.C.

Installed Clearance: Left: 0 inches, Right: 0 inches, Back: 6 inches (152mm)

Controls:

- 120 VAC, 1 Phase, 50/60 Hz

Electrical: Unless otherwise specified, Field Wire Electrical Connection to be 120 VAC, 1 Phase, 50/60 Hz with ground wire. Furnished with 4 1/2 foot cord with 3-prong plug. Maximum amps 4.0.

Drain: 2" IPS piped to open floor drain. No Solid Connection. 24" length before open air gap opening (no bends or elbows)

Gas: 3/4" IPS supply line required

Generator Water: 3/8" O.D. tubing at 25-50 PSI (170-345 kPa)

Condensing Water: 3/8" O.D. tubing at 25-50 PSI (170-345 kPa)

OPTIONS/ACCESSORIES

- 220 VAC, 1 Phase, 50/60 Hz Controls
- 120 Minute Timer
- Correctional Package

**INTENDED FOR COMMERCIAL USE ONLY.
NOT FOR HOUSEHOLD USE.**



1100 Old Honeycutt Road, Fuquay-Varina, NC 27526
(919) 762-1000 www.southbendnc.com