



# PR67A-D2

## 67" Pizza Prep Table with One Door and Two Drawers



PR67A-D2  
08/14/19  
Item # 13497

### W x D x H

67" x 32.25" x 43.5"\*  
\*to work surface with 4" casters



### Dimensions / Capacity

<b>Interior Storage Capacity</b> (CF) (AHAM)	19.9ft <sup>3</sup>
<b>Overall Width x Depth</b>	67" x 32.25"
<b>Height</b> (including 6" casters)	43.5"
<b>Depth with Cutting Board Installed</b> (including 1" bumper)	36"
<b>Door Opening Width x Height</b>	22.5" x 23"
<b>Depth with Door Fully Open</b> (including 1" bumper)	57.75"
<b>Depth with Drawer Fully Open</b> (including 1" bumper)	57.5"
<b>Adjustable Shelves</b>	2
<b>Shelf Dimensions</b> (W x D)	24.75" x 25.5"
<b>Pan Capacity</b> (# of 1/3rd size x 4" deep)	9
<b>Maximum Pan Depth</b>	6"
<b>Crated Weight</b>	462 lbs.
<b>Crated Length x Width x Height</b>	69" x 34.75" x 45"

### Two-Section PR67A-D2

### Electrical / Refrigeration

<b>Voltage</b>	115/60/1
<b>HACR Breaker</b>	15.0 Amps
<b>Electrical Connection</b> (NEMA)	5-15P Ⓢ
<b>Voltage Range</b>	104-126
<b>Ambient Temp. Range</b>	45° to 100°F
<b>Control Setpoint Range</b>	14° to 45°F
<b>Amperage</b>	6
<b>Energy Consumption</b> (kWh/day) @NSF	5.4
<b>Heat Rejection</b> (BTU/Hr.) @NSF	767
<b>Approx. Nominal Compres.</b> BTU/HR (HP)	1360(1/3HP)
<b>Refrigerant / Charge Amount</b> (oz)	R290 (3.2 oz)

### Two-Section PR67A-D2

Item #: \_\_\_\_\_  
 Project: \_\_\_\_\_  
 Qty: \_\_\_\_\_  
 AIA#: \_\_\_\_\_

## Features

- ▶ Engineered to maintain NSF-7 temperatures in 100°F ambient. (Certified to NSF-7 temperatures in 86°F ambient.)
- ▶ Rail utilizes an adjustable ducted air distribution system to distribute air evenly and maintain product temperature
- ▶ Stainless steel interior
  - Environmentally friendly R290 hydrocarbon refrigerant
  - Stainless steel exterior front, sides and top
  - Solid state digital controller with temperature alarms and LED display (Fahrenheit or Celsius)
  - Rail utilizes a unique ducted air distribution system to distribute air evenly and maintain product temperature
  - Cabinet, doors, and drawers are insulated with 2" of CFC free, foamed in place polyurethane
  - Drawer slides are constructed of 14 gauge stainless steel with acetal rollers
  - Drawer frames are constructed of 16 gauge stainless steel and securely fastened to cabinet
  - Drawers have a 250 lb. dynamic load rating
  - Drawers will accommodate (2) 12" x 20" x 6" deep pans (pans by others)
  - Provided with a full complement of polycarbonate plastic 1/3rd size pans, 4" deep and adapter bars
  - Front breating air flow design
  - Extruded aluminum flush mount drawer handle
  - Magnetic drawer gasket is easily removable for cleaning
  - 67" x 19" x 1/2" thick white polyethylene cutting board is standard
  - Two epoxy coated shelves per door section are standard
  - Evaporator coils are epoxy electrocoated (E-Coat) to help fight corrosion
  - Standard with 6" casters (two with brakes)
  - 10 ft. cord and plug

### Options

- 3.38" Casters
- Divider bar
- Overshelves
- Additional epoxy shelves
- Stainless steel shelves

### Warranty

\* 3 Year - parts and Labor on entire machine.  
 5 Year - Parts on Compressor  
 Valid in United States, Canada, Puerto Rico and U.S. Territories. Contact factory for warranty in other countries.

Note: Made to order. Allow 4-6 weeks.

*Hoshizaki reserves the right to change specifications without notice.*



# PR67A-D2

## 67" Pizza Prep Table with One Door and Two Drawers



PR67A-D2  
08/14/19  
Item # 13497

FRONT VIEW

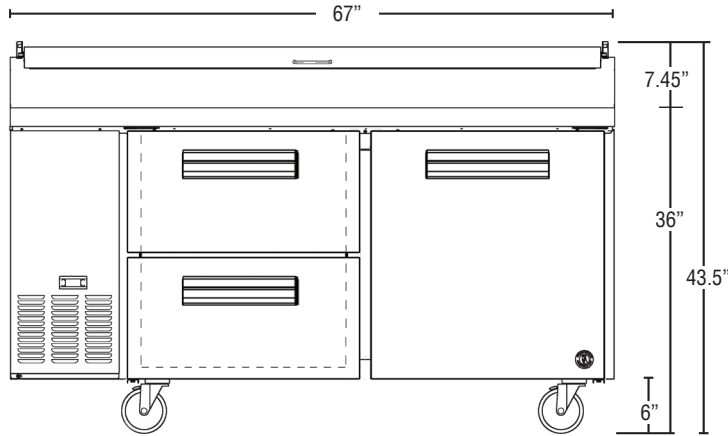

SIDE VIEW

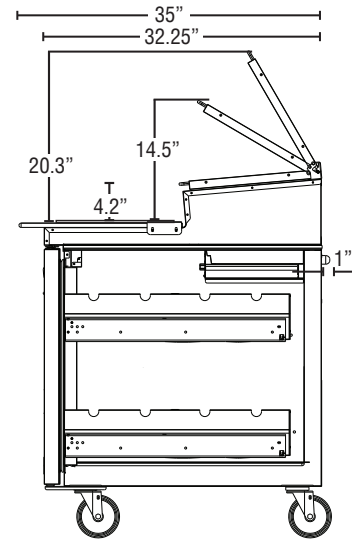

PLAN VIEW

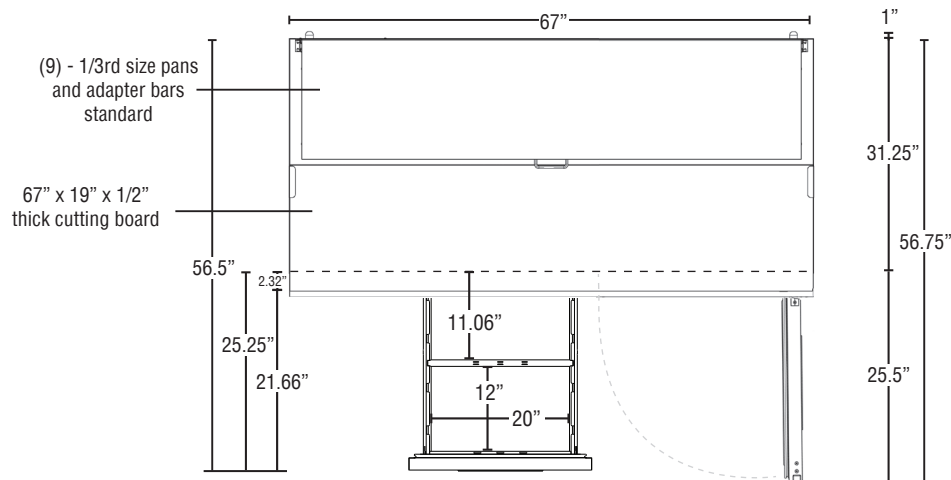

### Cabinet Construction

The exterior cabinet top, front, and sides, are constructed of high quality stainless steel. The exterior back and bottom are constructed of coated steel. The cabinet interior back and sides are stainless steel with an ABS ceiling and stainless steel floor. Mounted on anodized aluminum pilasters the shelves are adjustable in 1/2" increments. Cabinet walls and doors are insulated with 2" of foamed in place polyurethane. 6" polyolefin stem casters (two with brakes) are standard. The raised refrigerated rail is constructed of stainless steel interior and exterior (except back is galvanized steel). The rail is air cooled and utilizes a unique patent pending ducted air distribution system to distribute air evenly and maintain product temperature at safe levels. The rail will accommodate 1/6th, 1/3rd, 1/2 and full size pans 6" deep. Pans are located 1.5" below the front of the rail to assist in access to food product. An insulated, stainless steel, one piece hinged, lid is standard. Pizza preparation table is supplied with a 67" x 19" x 1/2" thick N.S.F. approved white polyethylene cutting board.

### Drawer Construction

Drawer fronts are constructed of high grade stainless steel inside and out and are insulated with 2" CFC free foamed in place polyurethane. Each drawer accommodates (2) 12" X 20" X 6" deep pans (pans by others). Drawer module frames are formed of 16 gauge stainless steel all welded construction and securely fastened in the cabinet. The drawer slides are constructed of 14 gauge stainless steel with delrin nylon rollers to prevent metal to metal contact between the drawer slides and help reduce wear. The drawer slides have a dynamic load capacity of 250 pounds. Drawers are provided with a one-piece extruded aluminum flush mount handle. Snap-in magnetic drawer gaskets are durable and easily removed for cleaning.

### Door Construction

Door is constructed of high grade stainless steel exterior with an ABS interior liner. Hoshizaki's exclusive "stepped" design protects the recessed gasket while product is removed from the cabinet. Door is provided with a one piece, extruded aluminum, flush mount handle. Spring assisted self-closing door is equipped with a stay open feature past 90 degrees. Snap-in magnetic door gaskets are durable and easily removed for cleaning. Field reversible door hinging is standard.

### Refrigeration System

Front breathing refrigeration system allows unit to be built into any enclosure with zero clearance at the side or rear. The high efficiency refrigeration system is self-contained with an epoxy electrocoated (E-Coat) evaporator coil for extended life. Condensate removal is accomplished with an energy efficient non-electric evaporation system. A capillary tube controls the flow of environmentally friendly R290 refrigerant through the evaporator. Unit uses a heated, time initiated defrost to eliminate any ice on the evaporator coil. An innovative ducted air distribution system distributes air evenly around food product in the rail. Engineered to maintain NSF-7 temperatures in 100°F ambient. (Certified to NSF-7 temperatures in 86°F ambient.) Pizza preparation tables are supplied with a full complement of N.S.F. approved polycarbonate plastic, 1/3rd size pans, 4" deep and stainless steel adapter bars. 115 volt units are equipped with a ten foot cord and NEMA rated plug (20.0 amps or less).